

Use of FastenMaster FrameFAST® Structural Wood Screw Fasteners to Provide Uplift & Lateral Resistance to Wood Trusses & Rafters Attached to the Tops of Walls - Limit States Design

TER No. 1608-02

OMG, Inc.  
d/b/a/ FastenMaster  
153 Bowles Road  
Agawam, MA 01001  
800-518-3569  
[fastenmaster.com](http://fastenmaster.com)  
[mguthrie@olyfast.com](mailto:mguthrie@olyfast.com)

Issue Date: October 18, 2016  
Updated: January 4, 2019  
Subject to Renewal: July 1, 2019

**DIVISION: 06 00 00 – WOOD, PLASTICS AND COMPOSITES**  
Section: 06 00 90 – Wood and Plastic Fastenings

#### 1. Product Evaluated:

- 1.1. FastenMaster FrameFAST® Structural Wood Screw (FrameFAST® fasteners)
- 1.2. For the most recent version of this Technical Evaluation Report (TER), visit [drjengineering.org](http://drjengineering.org). For more detailed state professional engineering and code compliance legal requirements and references, visit [drjengineering.org/statelaw](http://drjengineering.org/statelaw).
- 1.3. Douglas Consultants Inc. has collaborated with DrJ through the review and evaluation of test results and analysis methods as they affect the character of this engineering evaluation and conformity to the appropriate codes. DrJ and Douglas Consultants Inc. are fully compliant with all state and provincial professional-engineering and code-compliance laws.
- 1.4. This TER can be used to obtain product approval in any country that is an IAF MLA Signatory (all countries found [here](#)) and covered by an [IAF MLA Evaluation](#) per the [Purpose of the MLA](#) (as an example, see [letter to ANSI](#) from the Standards Council of Canada). Manufacturers can go to jurisdictions in the U.S., Canada and other [IAF MLA Signatory Countries](#) and have their products readily approved by authorities having jurisdiction using [DrJ's ANSI accreditation](#).

***DrJ is a Professional Engineering Approved Source***

 **Learn more about DrJ's Accreditation**

- DrJ is an ISO/IEC 17065 accredited product certification body through ANSI Accreditation Services.
- DrJ provides certified evaluations that are signed and sealed by a P.E.
- DrJ's work is backed up by professional liability insurance.
- DrJ is fully compliant with *IBC* Section 1703.

## Technical Evaluation Report (TER)

- 1.5. Building code regulations require that evaluation reports are provided by an approved agency meeting specific requirements, such as those found in [IBC Section 1703](#). Any agency accredited in accordance with ANSI ISO/IEC 17065 meets this requirement within ANSI's scope of accreditation. For a list of accredited agencies, visit ANSI's [website](#). For more information, see [drjcertification.org](#).
- 1.6. Requiring an evaluation report from a specific private company (i.e. ICC-ES, IAPMO, CCMC, DrJ, etc.) can be viewed as discriminatory and is a violation of international, federal, state, provincial and local anti-trust and free trade regulations.
- 1.7. DrJ's code compliance work:
  - 1.7.1. Conforms to code language adopted into law by individual states and any relevant consensus based standard such as an ANSI or ASTM standard.
  - 1.7.2. Complies with accepted engineering practice, all professional engineering laws and by providing an engineer's seal DrJ takes professional responsibility for its specified scope of work.

### 2. Applicable Codes and Standards:<sup>1</sup>

- 2.1. *2015 National Building Code of Canada (NBC)*
- 2.2. *CAN/CSA-O86-14 – Engineering Design in Wood*
- 2.3. *ASTM A153 – Standard Specification for Zinc Coating (Hot-Dip) on Iron and Steel Hardware*
- 2.4. *ASTM D1761 – Standard Test Methods for Mechanical Fasteners in Wood*
- 2.5. *ASTM F1575 – Standard Test Method for Determining Bending Yield Moment of Nails*
- 2.6. *ASTM F606 – Standard Test Method for Determining Properties of Fasteners*

### 3. Performance Evaluation:

- 3.1. FrameFAST® fasteners were evaluated, using assembly tests to derive factored design values, as an alternate means of attaching metal-plate-connected wood trusses and rafters to the tops of walls for the purpose of providing uplift and lateral load resistance. The following conditions were evaluated:
  - 3.1.1. Withdrawal strength of FrameFAST® fasteners for use as an alternative to toe-nail connections, metal hurricane and seismic clips/straps, or nails in tension (uplift) loaded applications.
  - 3.1.2. Shear strength of FrameFAST® fasteners for use as an alternative to toe-nail connections, hurricane and seismic clips/straps, or nails in shear (lateral) loaded applications either parallel or perpendicular to wood grain.
  - 3.1.3. Head-pull-through strength of FrameFAST® fasteners for use as an alternative to toe-nail connections, hurricane and seismic clips/straps or nails in tension (uplift) loaded applications.
- 3.2. Connections other than those addressed in [Section 3](#) are outside the scope of this TER.
- 3.3. Any code compliance issues not specifically addressed in this section are outside the scope of this TER.

---

<sup>1</sup> Unless otherwise noted, all references in this TER are from the 2015 version of the *NBC* and the standards referenced therein, including, but not limited to, *CSA O86-14*.

## Technical Evaluation Report (TER)

### 4. Product Description and Materials:

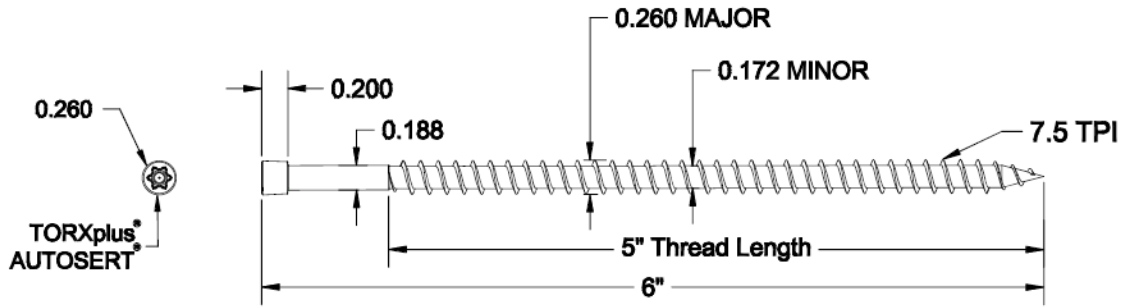

**Figure 1:** FrameFAST® Fastener Specification (dimensions in inches)

- 4.1. FrameFAST® fasteners are manufactured with modified 10B21 carbon steel wire conforming to the manufacturer’s specifications and are coated with a proprietary finish.
- 4.2. FrameFAST® fasteners are manufactured using a standard cold-formed process followed by a heat-treating process.
- 4.3. FrameFAST® fasteners are approved for use in interior and exterior conditions and in pressure-treated wood.
- 4.4. In-plant quality-control procedures, under which the FrameFAST® fasteners are manufactured, are audited through an inspection process performed by an approved agency.
- 4.5. The FrameFAST® fasteners evaluated in this TER are designated as follows:

Fastener	Fastener Designation	Fastener Length <sup>1</sup> mm	Thread Length <sup>1</sup> mm	Head Diameter mm	Head Height mm	Shank Diameter <sup>2</sup> mm	Minor Thread (Root) Diameter mm	Major Thread Diameter mm	Minimum Yield <sup>2</sup> (f <sub>y</sub> ) MPa
FrameFAST®	FMFF006	152	127	6.6	5.1	4.8	4.4	6.6	1 150

1. Fastener length is measured from the underside of the head to the tip. Thread length includes tapered tip (see [Figure 1](#)).  
2. Yield strength value determined at minor root diameter.

**Table 1:** Fastener Designation for the Evaluated FrameFAST® Fasteners

### 5. Applications:

- 5.1. FrameFAST® fasteners are used to attach minimum 1 1/2" (38 mm) wide wood trusses and sawn lumber rafters to wood walls that meet the requirements of *NBC* Section 9.23 for wood structural framing members. The fasteners provide resistance to uplift or lateral loads applied parallel and/or perpendicular to the wall or structural framing member.
  - 5.1.1. Walls shall consist of a single or double top plate designed in accordance with *NBC* Section 9.23.11.
  - 5.1.2. See [Table 2](#) for the design procedure and the FrameFAST® fasteners’ allowable design values.
  - 5.1.3. See [Section 6](#) for installation requirements.
  - 5.1.4. FrameFAST® fasteners are used in buildings requiring wind and seismic analysis in accordance with *NBC* Section 4.1.7 and 4.1.8.
- 5.2. Design Concepts and Resistances
  - 5.2.1. The uplift and lateral resistance [parallel (F1) and perpendicular (F2)] to the plane of the wall or structural member, [Figure 2](#) are provided in [Table 2](#) for FrameFAST® fasteners. Resistances are applicable to fasteners installed in accordance with the procedures described in [Section 6](#). Resistances are applicable to both single- and double-top-plate applications as shown in [Figure 3](#) and [Figure 4](#).

## Technical Evaluation Report (TER)

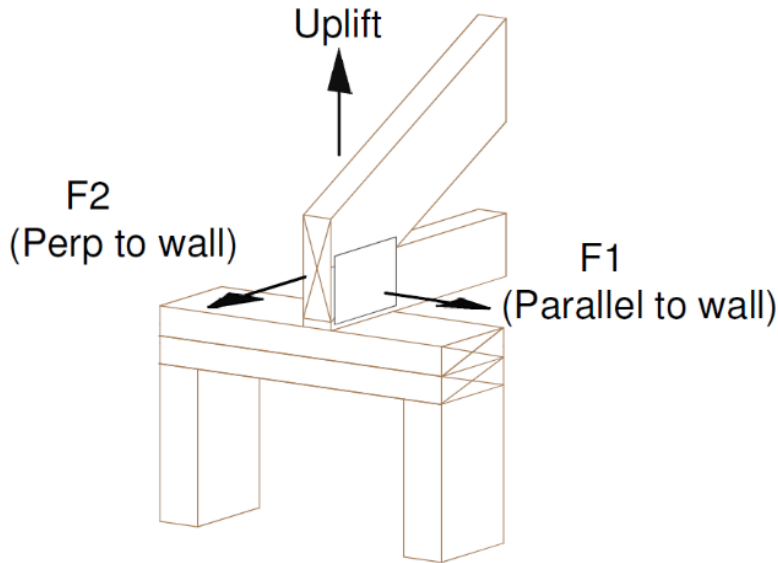

**Figure 2:** Uplift & Lateral Load Orientations

Fastener Designation	Penetration into Truss/Rafter/Wood Structural Support <sup>1</sup> (mm)	Visually Graded Lumber (Relative density) <sup>2, 3</sup>	Specified Uplift <sup>4, 5, 6</sup> (kN)	Specified Lateral Resistance <sup>5, 6</sup> (kN)	
				F1 – Parallel to Wall	F2 – Perpendicular to Wall
FMFF006	63	Southern Pine (0.55)	3.7	2.0	3.5
		Douglas Fir-Larch (0.50)	3.5	2.2	3.2
		Spruce-Pine-Fir/ Hem-Fir (0.42)	3.2	2.4	2.9

1. Wood truss and rafter members shall be a minimum of 38 mm (1.5") thickness. Design of truss and rafter members by others.  
 2. Equivalent relative density of structural composite lumber (SCL) shall be equal to or greater than the relative densities provided in this table. Refer to product information from SCL manufacturer.  
 3. For applications involving members with different relative densities, use a resistance corresponding to a lower relative density. Install screws so that the threaded part is half in the top plates, half in the truss members.  
 4. Use reduction factor of 0.80 when connecting each ply of multi-ply trusses to the top plate.  
 5. Specified loads shall be multiplied by the appropriate factors per Chapter 12 of CSA-086.  
 6. An increase of 1.15 for short term load duration may be applied where appropriate. See Table 5.3.2.2 of CSA-086.

**Table 2:** Specified Uplift & Lateral Resistance of FrameFAST® Fasteners for Selected Wood Relative Densities

**5.2.2.** Where it is anticipated that loads will be applied to a single fastener simultaneously in more than one direction, additional evaluation is required to account for the combined effect of these loads using the provisions of CAN/CSA O86.

**5.2.2.1.** Consult a professional engineer, as needed, for complex design conditions.

## Technical Evaluation Report (TER)

### 6. Installation:

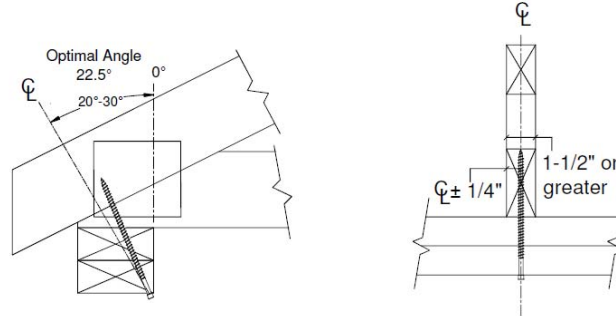

**Figure 3:** Installation of FrameFAST® Fasteners on Wood Truss or Rafter to Double Top Plate

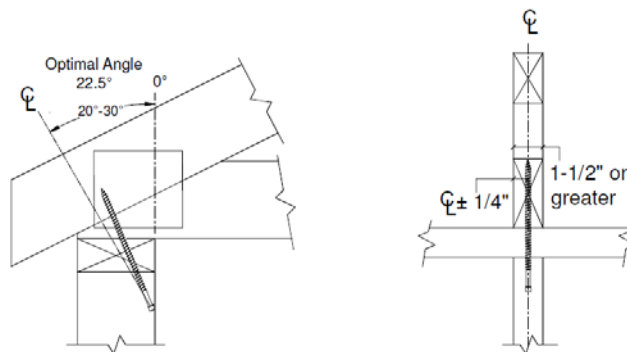

**Figure 4:** Installation of FrameFAST® Fasteners on Wood Truss or Rafter to Single Top Plate

- 6.1. Installation shall comply with the manufacturer's installation instructions and this TER. In the event of a conflict between the manufacturer's installation instructions and this TER, the more restrictive shall govern.
- 6.2. Select a FrameFAST® fastener with a length sufficient to fully embed 63 mm of the fastener length into the truss or rafter, while conserving at least 60 mm of thread in the top plates and stud. See [Figure 3](#) and [Figure 4](#) for guidance.
- 6.3. Install one (1) FrameFAST® fastener upward through the wall top plates or wood structural framing member at the bottom corner of the top plates and into the center of the wood truss or rafter. The fastener should be installed at a 20°-30° angle and should penetrate the wood truss or rafter within 6 mm of the centerline. See [Figure 3](#) and [Figure 4](#).
  - 6.3.1. If the wood truss or rafter is located directly over a top plate splice, offset the fastener 6 mm to one side of the splice and insert the fastener upward through the wall top plates or wood structural framing member at the bottom corner of the top plates and into the center of the truss or rafter. The fastener should be installed at a 20°-30° angle.
- 6.4. Use a 1/2" (12.7 mm) low RPM/high torque drill to drive the fastener head flush with the surface of the wall framing or wood structural framing member.

### 7. Test and Engineering Substantiating Data:

- 7.1. FrameFAST® fastener testing conducted by SBCRI, under contract with Qualtim, Inc., for the following conditions:
  - 7.1.1. Uplift capacity of FrameFAST® fasteners as evaluated for head pull through and withdrawal of fasteners.
  - 7.1.2. FrameFAST® fastener performance when used as a truss hold-down.

## Technical Evaluation Report (TER)

- 7.1.3. FrameFAST® fastener performance when loaded laterally.
- 7.2. Material property testing, conducted by the University of Montana - Wood Science Laboratory, 2016
- 7.3. *CAN/CSA-O86-14 – Engineering Design in Wood.*
- 7.4. The product(s) evaluated by this TER fall within the scope of one or more of the model, state or local building codes for building construction. The testing and/or substantiating data used in this TER is limited to buildings, structures, building elements, construction materials and civil engineering related specifically to buildings.
- 7.5. The provisions of model, state or local building codes for building construction do not intend to prevent the installation of any material or to prohibit any design or method of construction. Alternatives shall use consensus standards, performance-based design methods or other engineering mechanics based means of compliance. This TER assesses compliance with defined standards, accepted engineering analysis, performance-based design methods, etc. in the context of the pertinent building code requirements.
- 7.6. Some information contained herein is the result of testing and/or data analysis by other sources, which DrJ relies on to be accurate, as it undertakes its engineering analysis.
- 7.7. DrJ has reviewed and found the data provided by other professional sources are credible. The information in this TER conforms with DrJ's procedure for acceptance of data from approved sources.
- 7.8. DrJ's responsibility for data provided by approved sources conforms with [IBC Section 1703](#) and any relevant professional engineering law.
- 7.9. Where appropriate, DrJ relies on the derivation of design values, which have been codified into law through codes and standards (e.g., *IRC, WFCM, IBC, SDPWS, NDS, ACI, AISI, PS-20, PS-2*, etc.). This includes review of code provisions and any related test data that aids in comparative analysis or provides support for equivalency to an intended end-use application. Where the accuracy of design values provided herein is reliant upon the published properties of commodity materials (e.g. lumber, steel, concrete, etc), DrJ relies upon grade/properties provided by the raw material supplier to be accurate and conforming to the mechanical properties defined in the relevant material standard.

## 8. Findings:

- 8.1. When used in accordance with the provisions of this TER and the provisions of the applicable building codes defined in [Section 2](#), FrameFAST® fasteners have the factored design value properties defined herein and are approved for use as an alternative to those fasteners prescribed by the applicable code.
- 8.2. *NBC* Section 1.2.1 states:
- 1.2.1 Compliance with this Code**
- 1) Compliance with this Code shall be achieved by
- a) complying with the applicable acceptable solutions in Division B (see Note A-1.2.1.1.(1)(a)), or
- b) using alternative solutions that will achieve at least the minimum level of performance required by Division B in the areas defined by the objectives and functional statements attributed to the applicable acceptable solutions (see Note A-1.2.1.1.(1)(a)).
- 2) For the purposes of compliance with this Code as required in Clause 1.2.1.1.(1)(b), the objectives and functional statements attributed to the acceptable solutions in Division B shall be the objectives and functional statements referred to in Subsection 1.1.2. of Division B.
- 8.3. *NBC* Section 2.3 includes additional guidance for Alternative Solutions.
- 8.4. This product has been evaluated with the codes listed in [Section 2](#), and is compliant with all known provincial building codes. Where there are known variations in provincial codes that are applicable to this evaluation, they are listed here:
- 8.4.1. No known variations
- 8.5. This TER uses professional engineering law, the building code, ANSI/ASTM consensus standards and generally accepted engineering practice as its criteria for all testing and engineering analysis. DrJ's professional engineering work falls under the jurisdiction of the relevant association of professional engineers, when signed and sealed.

## Technical Evaluation Report (TER)

### 9. Conditions of Use:

- 9.1. Where required by the authority having jurisdiction (AHJ) in which the project is to be constructed, this TER and the installation instructions shall be submitted at the time of permit application.
- 9.2. Any generally accepted engineering calculations needed to show compliance with this TER shall be submitted to the code official for review and approval.
- 9.3. Design loads shall be determined in accordance with the building code adopted by the jurisdiction in which the project is to be constructed and/or by the Building Designer (e.g., Owner, Registered Design Professional, etc.).
- 9.4. The FrameFAST® fasteners covered in this TER shall be installed in accordance with this report and the manufacturer's installation instructions.
  - 9.4.1. For conditions not covered in this TER, connections shall be designed in accordance with accepted engineering practice.
- 9.5. Manufacturer's installation instructions shall be shipped to the jobsite with the materials or otherwise be available on the jobsite for inspection.
- 9.6. Structural framing members connected with FrameFAST® fasteners shall be designed in accordance with the requirements of their specific design standards/specifications as referenced in the building code adopted by the jurisdiction in which the project is to be constructed.
- 9.7. Loads applied shall not exceed those recommended by the manufacturer or as defined in this TER.
- 9.8. FastenMaster products are produced by OMG, Inc. at its facility located in Agawam, Massachusetts.
- 9.9. FrameFAST® fasteners are produced under a quality control program subject to periodic inspections.
- 9.10. Design
  - 9.10.1. Building Designer Responsibility
    - 9.10.1.1. Unless the AHJ allows otherwise, the Construction Documents shall be prepared by a Building Designer (e.g., Registered Design Professional) for the Building and shall be in accordance with *NBC* Section 2.2.1.2.
    - 9.10.1.2. The Construction Documents shall be accurate and reliable and shall provide the location, direction and magnitude of all applied loads and shall be in accordance with *NBC* Section 2.2.4.3.
  - 9.10.2. Construction Documents
    - 9.10.2.1. Construction Documents shall be submitted to the Building Official for approval and shall contain the plans, specifications and details needed for the Building Official to approve such documents.
- 9.11. Responsibilities
  - 9.11.1. The information contained herein is a product, material, detail, design and/or application TER evaluated in accordance with the referenced building codes, testing and/or analysis through the use of accepted engineering practice, experience and technical judgment.
  - 9.11.2. DrJ TERs provide an assessment of only those attributes specifically addressed in the Products Evaluated or Code Compliance Process Evaluated sections.
  - 9.11.3. The engineering evaluation was performed on the dates provided in this TER, within DrJ's professional scope of work.
  - 9.11.4. This product is manufactured under a third-party quality control program.
  - 9.11.5. The actual design, suitability and use of this TER, for any particular building, is the responsibility of the Owner or the Owner's authorized agent, and the TER shall be reviewed for code compliance by the Building Official.
  - 9.11.6. The use of this TER is dependent on the manufacturer's in-plant QC, the ISO/IEC 17020 third-party quality assurance program and procedures, proper installation per the manufacturer's instructions, the

## Technical Evaluation Report (TER)

Building Official's inspection and any other code requirements that may apply to demonstrate and verify compliance with the applicable building code.

### 10. Identification:

- 10.1. The fasteners described in this TER are identified by the designation "FrameFAST®" on the packaging material bearing the manufacturer's name, product name, TER number, and other information to confirm code compliance.
- 10.2. The packaging shall include OMG's name and address, fastener size, third-party inspection agency, and TER number.
- 10.3. Additional technical information can be found at [fastenmaster.com](http://fastenmaster.com).

### 11. Review Schedule:

- 11.1. This TER is subject to periodic review and revision. For the most recent version of this TER, visit [drjengineering.org](http://drjengineering.org).
- 11.2. For information on the current status of this TER, contact [DrJ Engineering](http://DrJ Engineering).



- [Mission and Professional Responsibilities](#)
- [Product Evaluation Policies](#)
- [Product Approval – Building Code, Administrative Law and P.E. Law](#)