

Approved. Sealed. Code Compliant.

Technical Evaluation Report

TER 1909-04

TRUFAST® Structural Insulated Panel
(SIP) Fasteners

**Altenloh, Brinck & Company
U.S., Inc.**

Products:

**SIPTP
SIPLD
SIPHD**

Issue Date:

February 10, 2020

Revision Date:

July 6, 2020

Subject to Renewal:

April 1, 2021



COMPANY
INFORMATION:

Altenloh, Brinck & Company U.S., Inc.

2105 County Road 12C

Bryan, OH 43506

419-636-6715

www.trufast.com

DIVISION: 03 00 00 - CONCRETE

SECTION: 03 15 00 - Concrete Accessories

DIVISION: 04 00 00 - MASONRY

SECTION: 04 05 23 - Masonry Accessories

DIVISION: 05 00 00 - METALS

SECTION: 05 05 23 - Metal Fastenings

DIVISION: 06 00 00 - WOOD, PLASTICS AND COMPOSITES

SECTION: 06 05 23 - Wood, Plastic, and Composite Fastenings

1 PRODUCTS EVALUATED¹

- 1.1 SIPTP
- SIPLD
- SIPHD

2 APPLICABLE CODES AND STANDARDS^{2,3}

2.1 Codes

- 2.1.1 *IBC—12, 15, 18: International Building Code®*
- 2.1.2 *IRC—12, 15, 18: International Residential Code®*

2.2 Standards and Referenced Documents

¹ Building codes require data from valid [research reports](#) be obtained from [approved sources](#). Agencies who are accredited through ISO/IEC 17065 have met the [code requirements](#) for approval by the [building official](#). DrJ is an ISO/IEC 17065 [ANAB-Accredited Product Certification Body - Accreditation #1131](#).

Through ANAB accreditation and the [IAF MLA](#), DrJ certification can be used to obtain product approval in any [jurisdiction](#) or country that has [IAF MLA Members & Signatories](#) to meet the [Purpose of the MLA](#) - "certified once, accepted everywhere."

Building official approval of a licensed [registered design professional](#) (RDP) is performed by verifying the RDP and/or their business entity complies with all professional engineering laws of the relevant [jurisdiction](#). Therefore, the work of licensed RDPs is accepted by [building officials](#), except when plan (i.e., peer) review finds an error with respect to a specific section of the code. Where this TER is not approved, the [building official](#) responds in writing stating the reasons for [disapproval](#).

For more information on any of these topics or our mission, product evaluation policies, product approval process, and engineering law, visit drjcertification.org or call us at 608-310-6748.

² Unless otherwise noted, all references in this TER are from the 2018 version of the codes and the standards referenced therein (e.g., *ASCE 7, NDS, ASTM*). This material, design, or method of construction also complies with the 2000-2015 versions of the referenced codes and the standards referenced therein.

³ All terms defined in the applicable building codes are italicized.



- 2.2.1 *ACI 318: Building Code Requirements for Structural Concrete*
- 2.2.2 *AISI S100: North American Specification for the Design of Cold-formed Steel Structural Members*
- 2.2.3 *AISI S904: Standard Test Methods for Determining the Tensile and Shear Strength of Screws*
- 2.2.4 *ANSI/AWC NDS: National Design Specification (NDS) for Wood Construction*
- 2.2.5 *ANSI/SDI-RD: Standard for Steel Roof Deck*
- 2.2.6 *ASTM C90: Standard Specification for Loadbearing Concrete Masonry Units*
- 2.2.7 *ASTM D1761: Standard Test Methods for Mechanical Fasteners in Wood*
- 2.2.8 *ASTM D6294: Standard Test Method for Corrosion Resistance of Ferrous Metal Fastener Assemblies Used in Roofing and Waterproofing.*
- 2.2.9 *ASTM F1575: Standard Test Method for Determining Bending Yield Moment of Nails*
- 2.2.10 *DOC PS 2: Performance Standard for Wood-based Structural-use Panels*
- 2.2.11 *FM 4470: Approval Standard for Single-Ply Polymer-Modified Bitumen Sheet, Built-Up Roof (BUR) and Liquid Applied Roof Assemblies for Use in Class 1 and Noncombustible Roof Deck Construction*
- 2.2.12 *TMS 402: Building Code for Masonry Structures*

3 PERFORMANCE EVALUATION

- 3.1 TRUFAST® SIP Fasteners were tested and evaluated to determine their structural resistance properties, which were used to develop reference design values for allowable stress design (ASD). The following properties were evaluated:
 - 3.1.1 Bending yield in accordance with *ASTM F1575*.
 - 3.1.2 Tensile strength in accordance with *AISI S904*.
 - 3.1.3 Shear strength in accordance with *AISI S904*.
 - 3.1.4 Head pull-through in accordance with *ASTM D1761*.
 - 3.1.5 Withdrawal strength in accordance with *ASTM D1761*.
 - 3.1.6 Corrosion resistance of fasteners used in roof assemblies in accordance with *ASTM D6294*.
- 3.2 Use of fasteners in locations exposed to saltwater or saltwater spray is outside the scope of this TER.
- 3.3 Use of fasteners in cracked concrete is outside the scope of this TER.
- 3.4 Any code compliance issues not specifically addressed in this section are outside the scope of this TER.
- 3.5 Any engineering evaluation conducted for this TER was performed on the dates provided in this TER and within DrJ's professional scope of work.

4 PRODUCT DESCRIPTION AND MATERIALS

- 4.1 *Fasteners*
 - 4.1.1 SIPTP (thread point) fasteners are size No. 14 fasteners with a pancake head and a T-30 drive. The point is a threaded drill point. The SIPTP fastener is shown in Figure 1.

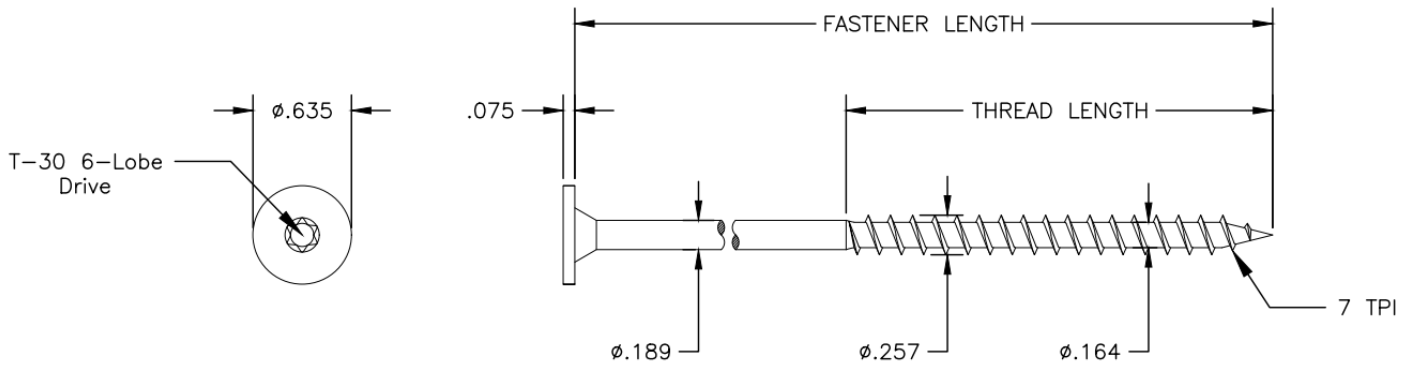

FIGURE 1. SIPTP FASTENER

4.1.2 SIPLD (light-duty) fasteners are size No. 14 fasteners with a pancake head and a T-30 drive. The point is a two-flute formed drill tip. The SIPLD fastener is shown in Figure 2.

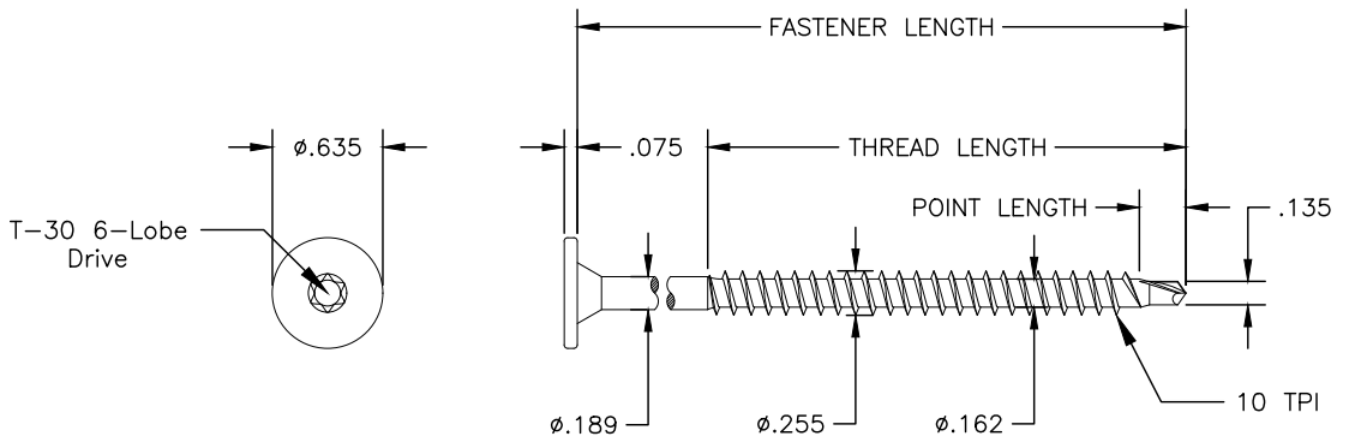

FIGURE 2. SIPLD FASTENER

4.1.3 SIPHD (heavy-duty) fasteners are size No. 14 fasteners with a pancake head and a T-30 drive. The point is a two-flute formed drill tip. The SIPHD fastener is shown in Figure 3.

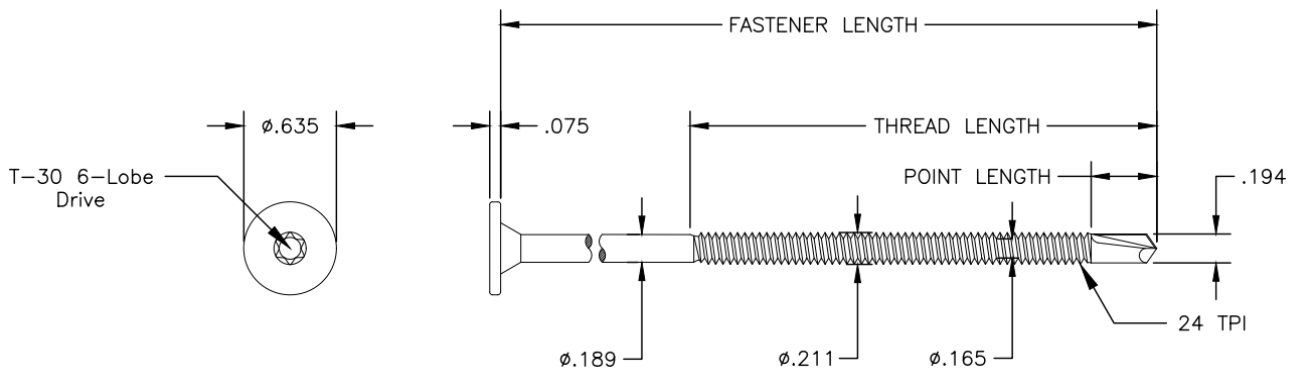

FIGURE 3. SIPHD FASTENER

4.1.4 SIP fasteners are coated with TRUFAST Tru-Kote™ coating.



4.1.4.1 SIP fasteners coated with TRUFAST Tru-Kote™ were tested and passed ASTM D6294 with less than 15% red rust after 15 cycles, in accordance with FM 4470.

4.1.5 The fasteners evaluated in this TER are set forth in Table 1, Table 2, and Table 3.

TABLE 1. SIPTP FASTENER SPECIFICATIONS

Fastener Name	Fastener Part Number	Head (in.)		Nominal Length ¹ (in.)	Thread Length ¹ (in.)	Shank Diameter ² (in.)	Thread Diameter (in.)		Nominal Bending Yield ³ , f _{yb} (psi)	Allowable Fastener Strength (lb.)		
		Diameter	Drive Type				Minor	Major		Tensile	Shear at Shank Diameter	Shear at Minor Diameter
SIPTP	SIPTP-2000	0.635	T-30	2.00	1.75	0.189	0.164	0.257	185,000	1,185	975	860
	SIPTP-2500			2.50								
	SIPTP-3000			3.00	2.00							
	SIPTP-3500			3.50								
	SIPTP-4000			4.00	2.75							
	SIPTP-4500			4.50								
	SIPTP-5000			5.00								
	SIPTP-5500			5.50								
	SIPTP-6000			6.00								
	SIPTP-6500			6.50								
	SIPTP-7000			7.00								
	SIPTP-7500			7.50								
	SIPTP-8000			8.00								
	SIPTP-8500			8.50								
	SIPTP-9000			9.00								
	SIPTP-10000			10.00								
	SIPTP-11000			11.00								
	SIPTP-12000			12.00								
	SIPTP-13000			13.00								
	SIPTP-14000			14.00								
SIPTP-15000	15.00											
SIPTP-16000	16.00											
SIPTP-18000	18.00											

SI: 1 in. = 25.4 mm, 1 lb. = 4.45 N, 1 psi = 0.00689 MPa

1. Fastener length is measured from the underside of the head to the tip. Thread length includes tapered tip (see Figure 1).
2. Shank diameter based on manufactured thickness. Finished dimensions are larger, due to the proprietary coatings added.
3. Nominal bending yield, F_{yb}, is measured along the threaded portion of the fastener. For the nominal bending yield of the fastener along the shank, take a 10% reduction.





TABLE 2. SIPLD FASTENER SPECIFICATIONS

Fastener Name	Fastener Part Number	Head (in.)		Nominal Length ¹ (in.)	Thread Length ¹ (in.)	Point Length (in.)	Shank Diameter ² (in.)	Thread Diameter (in.)		Nominal Bending Yield ³ , f _{yb} (psi)	Allowable Fastener Strength (lb.)		
		Diameter	Drive Type					Minor	Major		Tensile	Shear at Shank Diameter	Shear at Minor Diameter
SIPLD	SIPLD-2250	0.635	T-30	2.25	1.00	0.125	0.189	0.162	0.255	185,000	1,130	945	830
	SIPLD-3000			3.00	2.75	0.275							
	SIPLD-3250			3.25	1.50	0.125							
	SIPLD-3500			3.50	2.75	0.275							
	SIPLD-4000			4.00									
	SIPLD-4250			4.25	2.00	0.125							
	SIPLD-4500			4.50	2.75	0.275							
	SIPLD-5000			5.00									
	SIPLD-5250			5.25	2.50	0.125							
	SIPLD-5500			5.50	2.75	0.275							
	SIPLD-6000			6.00									
	SIPLD-6500			6.50									
	SIPLD-7000			7.00									
	SIPLD-7500			7.50									
	SIPLD-8000			8.00									
	SIPLD-8500			8.50									
	SIPLD-9000			9.00									
	SIPLD-9500			9.50									
	SIPLD-10000			10.00									
	SIPLD-11000			11.00									
SIPLD-12000	12.00												
SIPLD-13000	13.00												
SIPLD-14000	14.00												
SIPLD-15000	15.00												
SIPLD-16000	16.00												
SIPLD-18000	18.00												

SI: 1 in. = 25.4 mm, 1 lb. = 4.45 N, 1 psi = 0.00689 MPa

1. Fastener length is measured from the underside of the head to the tip. Thread length includes tapered tip (see Figure 2).
2. Shank diameter based on manufactured thickness. Finished dimensions are larger, due to the proprietary coatings added.
3. Nominal bending yield, F_{yb}, is measured along the threaded portion of the fastener. For the nominal bending yield of the fastener along the shank, take a 10% reduction.



TABLE 3. SIPHD FASTENER SPECIFICATIONS

Fastener Name	Fastener Part Number	Head (in.)		Nominal Length ¹ (in.)	Thread Length ¹ (in.)	Point Length (in.)	Shank Diameter ² (in.)	Thread Diameter (in.)		Nominal Bending Yield ³ , f_{yb} (psi)	Allowable Fastener Strength (lb.)		
		Diameter	Drive Type					Minor	Major		Tensile	Shear at Shank Diameter	Shear at Minor Diameter
SIPHD	SIPHD-2250	0.635	T-30	2.25	1.00	0.125	0.189	0.165	0.211	185,000	1,285	1,015	875
	SIPHD-3250			3.25	1.50								
	SIPHD-4250			4.25	2.00								
	SIPHD-4500			4.50	3.19	0.450							
	SIPHD-5250			5.25	2.50	0.125							
	SIPHD-6000			6.00	3.88	0.450							
	SIPHD-8000			8.00									
	SIPHD-9000			9.00									
	SIPHD-9750			9.75									
	SIPHD-11750			11.75									
	SIPHD-13750			13.75									

SI: 1 in. = 25.4 mm, 1 lb. = 4.45 N, 1 psi = 0.00689 MPa

1. Fastener length is measured from the underside of the head to the tip. Thread length includes tapered tip (see Figure 3).
2. Shank diameter based on manufactured thickness. Finished dimensions are larger, due to the proprietary coatings added.
3. Nominal bending yield, F_{yb} , is measured along the threaded portion of the fastener. For the nominal bending yield of the fastener along the shank, take a 10% reduction.

4.2 Substrate Materials

4.2.1 Wood

- 4.2.1.1 Solid sawn wood members connected with SIP fasteners shall consist of lumber species or species combinations having a specific gravity of at least 0.42.
- 4.2.1.2 Wood structural panels [plywood and oriented strand board (OSB)] connected with SIP fasteners shall have a specific gravity of at least 0.50. Wood structural panels shall comply with *DOC PS 1* or *DOC PS 2*.
- 4.2.1.3 Structural composite lumber (e.g., LVL, LSL, PSL, etc.) connected with SIP fasteners shall have an equivalent specific gravity of at least 0.50.

4.2.2 Steel

- 4.2.2.1 Steel must comply with one of the material standards provided in Section A3.1 of *AISI S100*.
- 4.2.2.2 Fasteners are approved for use with steel decking designed and constructed in accordance with *ANSI/SDI-RD*.

4.2.3 Concrete

- 4.2.3.1 Normal weight and lightweight structural concrete must comply with *IBC Section 1901.2*.
- 4.2.3.2 Concrete shall be uncracked for the service life of the fastener.

4.2.4 Masonry

- 4.2.4.1 Load-bearing concrete masonry units (CMU's) shall comply with *IBC Section 2114.3* and *IRC Section R606.2.1*.

4.2.4.2 CMU's shall be normal-weight and conform to *ASTM C90*.

5 APPLICATIONS

- 5.1 SIPTP fasteners are used for attaching structural insulated panels (SIPs) and Composite Insulation Board (nail base) to wood framing, concrete, and masonry block.
- 5.2 SIPLD fasteners are used for attaching SIPs and Composite Insulation Board (nail base) to wood framing, light gauge steel framing, concrete, and masonry block.
- 5.3 SIPHD fasteners are used for attaching SIPs and Composite Insulation Board (nail base) to cold-formed steel framing.
- 5.4 Where the application exceeds the limitations set forth herein, design shall be permitted in accordance with accepted engineering procedures, experience, and technical judgment.
- 5.5 *Design*
- 5.5.1 *Connections in Wood*
- 5.5.1.1 Design of SIPTP and SIPLD fasteners in wood connections is governed by the applicable code and the provisions for dowel-type fasteners in *NDS*. Unless otherwise noted, adjustment of the design stresses for the duration of load shall be in accordance with the applicable code.
- 5.5.1.1.1 Head pull-through design values are provided in Table 4.
- 5.5.1.1.2 Withdrawal design values are provided in Table 5, Table 6, Table 9, and Table 10.
- 5.5.1.2 Fasteners in wood shall follow in the minimum spacing, end distance, and edge distance requirements provided in Table 15.
- 5.5.2 *Connections in Steel*
- 5.5.2.1 Design of SIPLD and SIPHD fasteners in steel connections is governed by *IBC Section 2210* and the provisions for screw-type fasteners in Section J4 of *AISI S100*.
- 5.5.2.1.1 Allowable Strength Design (ASD) pull-out values are provided in Table 13 and Table 14.
- 5.5.2.1.2 Instructions for calculating Load Resistance Factored Design (LRFD) pull-out values are provided in the footnotes of Table 13 and Table 14.
- 5.5.2.2 Fasteners in steel shall follow the minimum edge distance, end distance, and spacing requirements provided in Table 16.
- 5.5.3 *Connections in Concrete*
- 5.5.3.1 Design of SIPTP and SIPLD fasteners in concrete connections is governed by *IBC Section 1901.3* and the provisions for anchoring to concrete in *ACI 318* Chapter 17.
- 5.5.3.1.1 Allowable pull-out values for resisting static tension loads are provided in Table 7 and Table 11.
- 5.5.3.1.2 The concrete shall remain uncracked for its service life and have a 28-day compressive strength as specified in Table 7 and Table 11.
- 5.5.3.2 For use in lightweight structural concrete, adjustments shall be made per *ACI 318* Section 17.2.6.
- 5.5.3.3 Fasteners in concrete shall follow the installation requirements of Table 17.
- 5.5.4 *Connections in Masonry (CMU Block)*
- 5.5.4.1 Design of SIPTP and SIPLD fasteners in masonry connections is governed by *IBC Section 2107* and the provisions for anchoring to masonry in *TMS 402*.
- 5.5.4.1.1 Allowable design values for resisting static tension loads are provided in Table 8 and Table 12.
- 5.5.4.1.1.1 Allowable tension loads apply when fastener is installed in grouted or ungrouted CMU block.

5.5.4.2 Fasteners in CMU block shall follow the installation requirements of Table 18.

5.6 SIP Fastener Reference Head Pull-Through Design Values

5.6.1 Reference design values for head pull-through for SIPTP and SIPLD fasteners are provided in Table 4.

TABLE 4. SIP FASTENER HEAD PULL-THROUGH DESIGN VALUES

Main Member Type (Specific Gravity)	Main Member Description	Head Pull-Through Design Value ¹ (lb.)
OSB ⁵ (0.50)	23/32" thick	345
	19/32" thick	146
	1/2" thick	100
	7/16" thick	85
Plywood ⁵ (0.50)	23/32" thick	380
	19/32" thick	265
	15/32" thick	175
SPF ² (0.42)	Dry Service Condition ^{3,4}	380
	Wet Service Condition ^{3,4}	265
DF-L ² (0.50)	Dry Service Condition ^{3,4}	555
	Wet Service Condition ^{3,4}	390

SI: 1 in. = 25.4 mm, 1 lb. = 4.45 N

1. Tabulated pull-through values shall be adjusted by all applicable adjustment factors per NDS, Table 11.3.1.
2. For wood species with a specific gravity between 0.42 and 0.50, use the tabulated values for specific gravity of 0.42. For wood species with a specific gravity greater than 0.50, use the tabulated values for specific gravity of 0.50.
3. Minimum 1.5" thickness.
4. The dry service condition is defined as lumber with an in-service moisture content of less than or equal to 19%. The wet service condition is defined as lumber with an in-service moisture content of greater than 19%.
5. Plywood and OSB shall comply with DOC PS 1 or DOC PS 2, respectively (e.g., APA Rated).



5.7 SIPTP Fastener Withdrawal & Pull-Out Values

5.7.1 Withdrawal design values for SIPTP fasteners in OSB and plywood are provided in Table 5.

TABLE 5. SIPTP WITHDRAWAL VALUES IN OSB & PLYWOOD

Main Member Type (Specific Gravity)	Main Member Nominal Thickness ¹ (in.)	Withdrawal Value ² (lb.)
OSB ³ (0.50)	23/32	110
	19/32	60
	1/2	40
	7/16	45
Plywood ³ (0.50)	23/32	155
	19/32	130
	15/32	85

SI: 1 in. = 25.4 mm, 1 lb. = 4.45 N

- Fastener penetrates through the full thickness of the board.
- Tabulated withdrawal values shall be adjusted by all applicable adjustment factors per *NDS*, Table 11.3.1.
- Plywood and OSB shall comply with *DOC PS 1* or *DOC PS 2*, respectively (e.g., APA Rated).



5.7.2 Reference withdrawal values for SIPTP fasteners in dimensional lumber and engineered wood are provided in Table 6.

TABLE 6. SIPTP REFERENCE WITHDRAWAL VALUES IN LUMBER & ENGINEERED WOOD (LB./IN.)

Main Member Type (Specific Gravity)	Main Member Service Condition ²	Fastener Installed in Face or Edge Grain	Penetration into Main Member ³ (in.)	Reference Withdrawal Value ^{4,5} (lb./in.)
SPF ¹ (0.42)	Dry	Face	1	175
			2	190
	Wet	Face	1	120
			1	120
DF-L ¹ (0.50)	Dry	Face	1	195
			1	150
	Wet	Face	1	135
LVL (0.50)	Dry	Face	1	140
		Edge		125
LSL (0.50)	Dry	Face	1	135

SI: 1 in. = 25.4 mm, 1 lb. = 4.45 N

- For wood species with a specific gravity between 0.42 and 0.50, use the tabulated values for specific gravity of 0.42. For wood species with a specific gravity greater than 0.50, use the tabulated values for specific gravity of 0.50.
- The dry service condition is defined as lumber with an in-service moisture content of less than or equal to 19%. The wet service condition is defined as lumber with an in-service moisture content of greater than 19%.
- Fastener penetration is the threaded length embedded in the main member, including the tip.
- The full design withdrawal value (W) is equal to: $W = w_1 + (L_T - 1)(w_2 - w_1)$; where w_1 = reference withdrawal corresponding to 1" penetration, L_T = embedded thread length (minimum 1"), and w_2 = reference withdrawal corresponding to 2" penetration.
- Tabulated withdrawal values shall be adjusted by all applicable adjustment factors per *NDS*, Table 11.3.1.

5.7.3 Allowable pull-out loads for SIPTP fasteners in concrete and concrete masonry units are provided in Table 7 and Table 8, respectively.

TABLE 7. SIPTP ALLOWABLE PULL-OUT LOADS IN CONCRETE (LB.)

Main Member	Minimum 28 Day Concrete Compressive Strength (psi)	Effective Embedment Depth ⁵ (in.)	Allowable Pull-Out Load ^{6,7} (lb.)
Concrete ^{1,2,3,4}	2,500	1	100
	4,000		165

SI: 1 in. = 25.4 mm, 1 lb. = 4.45 N

- Concrete remains uncracked for service life of fastener.
- For use in lightweight structural concrete, adjustments shall be made per ACI 318 Section 17.2.6.
- Critical edge distance is 3".
- Concrete thickness must be a minimum of 1.5 times the embedment.
- Fastener embedment is the threaded length embedded in the main member, including the tip.
- Single fastener with static tension load only.
- Allowable pull-out is determined by dividing the strength design value by a conversion factor (α) of 1.48. The conversion factor is based on the load combination: 1.2D + 1.6L, where Dead Load (D) = 30% and Live Load (L) = 70%. Adjustments shall be made where other load combinations control.

TABLE 8. SIPTP ALLOWABLE TENSION LOAD CMU BLOCK (LB.)

Main Member	Embedment Depth ¹ (in.)	Allowable Tension Load ^{2,3,3} (lb.)
CMU Block ⁴	1	175
SI: 1 in. = 25.4 mm, 1 lb. = 4.45 N 1. Fastener embedment is the threaded length embedded in the CMU block wall or web, including the tip. 2. Minimum edge distance is 2.5". 3. Allowable unit tension is determined by dividing the strength design value by a conversion factor (α) of 1.48. The conversion factor is based on the load combination: 1.2D + 1.6L, where Dead Load (D) = 30% and Live Load (L) = 70%. Adjustments shall be made where other load combinations control. 4. Standard concrete masonry unit block conforming to <i>ASTM C90</i> .		

5.8 *SIPLD Fastener Withdrawal & Pull-Out Values*

5.8.1 Withdrawal design values for SIPLD fasteners in OSB and plywood are provided in Table 9.

TABLE 9. SIPLD WITHDRAWAL VALUES IN OSB & PLYWOOD (LB.)

Main Member Type (Specific Gravity)	Main Member Nominal Thickness ¹ (in.)	Withdrawal Value ² (lb.)
OSB ³ (0.50)	23/32	155
	19/32	70
	1/2	45
	7/16	50
Plywood ³ (0.50)	23/32	180
	19/32	120
	15/32	80
SI: 1 in. = 25.4 mm, 1 lb. = 4.45 N 1. Fastener penetrates through the full thickness of the board. 2. Tabulated withdrawal values shall be adjusted by all applicable adjustment factors per <i>NDS</i> , Table 11.3.1. 3. Plywood and OSB shall comply with <i>DOC PS 1</i> or <i>DOC PS 2</i> , respectively (e.g., APA Rated).		

5.8.2 Reference withdrawal values for SIPLD fasteners in dimensional lumber and engineered wood are provided in Table 10.

TABLE 10. SIPLD REFERENCE WITHDRAWAL VALUES IN LUMBER & ENGINEERED WOOD (LB./IN.)

Main Member Type (Specific Gravity)	Main Member Service Condition ²	Fastener Installed in Face or Edge Grain	Penetration into Main Member ³ (in.)	Reference Withdrawal Value ^{4,5} (lb./in.)
SPF ¹ (0.42)	Dry	Face	1	140
			2	180
	Wet	Face	1	110
			2	125
DF-L ¹ (0.50)	Dry	Face	1	150
			2	205
	Wet	Face	1	165
			2	105
LVL (0.50)	Dry	Face	1	135
		Edge		115
LSL (0.50)	Dry	Face	1	140

SI: 1 in. = 25.4 mm, 1 lb. = 4.45 N

- For wood species with a specific gravity between 0.42 and 0.50, use the tabulated values for specific gravity of 0.42. For wood species with a specific gravity greater than 0.50, use the tabulated values for specific gravity of 0.50.
- The dry service condition is defined as lumber with an in-service moisture content of less than or equal to 19%. The wet service condition is defined as lumber with an in-service moisture content of greater than 19%.
- Fastener penetration is the threaded length embedded in the main member, including the tip.
- The full design withdrawal value (W) is equal to: $W = w_1 + (L_T - 1)(w_2 - w_1)$; where w_1 = reference withdrawal corresponding to 1" penetration, L_T = embedded thread length (minimum 1"), and w_2 = reference withdrawal corresponding to 2" penetration.
- Tabulated withdrawal values shall be adjusted by all applicable adjustment factors per *NDS*, Table 11.3.1.

5.8.3 Allowable pull-out loads for SIPLD fasteners in concrete and concrete masonry units are provided in Table 11 and Table 12, respectively.

TABLE 11. SIPLD ALLOWABLE PULL-OUT LOADS IN CONCRETE (LB.)

Main Member	Minimum 28 Day Concrete Compressive Strength (psi)	Effective Embedment Depth ⁵ (in.)	Allowable Pull-Out Load ^{6,7} (lb.)
Concrete ^{1,2,3,4}	2,500	1	70
	4,000		155
	5,000		160

SI: 1 in. = 25.4 mm, 1 lb. = 4.45 N

- Concrete remains uncracked for service life of fastener.
- For use in lightweight structural concrete, adjustments shall be made per *ACI 318* Section 17.2.6.
- Critical edge distance is 3".
- Concrete thickness must be a minimum of 1.5 times the embedment.
- Fastener embedment is the threaded length embedded in the main member, including the tip.
- Single fastener with static tension load only.
- Allowable pull-out is determined by dividing the strength design value by a conversion factor (α) of 1.48. The conversion factor is based on the load combination: 1.2D + 1.6L, where Dead Load (D) = 30% and Live Load (L) = 70%. Adjustments shall be made where other load combinations control.

TABLE 12. SIPLD ALLOWABLE TENSION LOADS CMU BLOCK (LB.)

Main Member	Embedment Depth ¹ (in.)	Allowable Tension Load ^{2,3} (lb.)
CMU Block ⁴	1	80

SI: 1 in. = 25.4 mm, 1 lb. = 4.45 N

- Fastener embedment is the threaded length embedded in the CMU block wall or web, including the tip.
- Minimum edge distance is 2.5".
- Allowable tension is determined by dividing the strength design value by a conversion factor (α) of 1.48. The conversion factor is based on the load combination: 1.2D + 1.6L, where Dead Load (D) = 30% and Live Load (L) = 70%. Adjustments shall be made where other load combinations control.
- Standard concrete masonry unit block conforming to *ASTM C90*

5.8.4 Allowable pull-out strength values (in lb.) for SIPLD fasteners in steel are provided in Table 13.

TABLE 13. SIPLD ALLOWABLE PULL-OUT STRENGTH DESIGN VALUES (LB.)

Minimum Tensile Strength of Steel ¹	Steel Designation ⁴	Design Steel Thickness ^{2,3}				
		0.024" (24 ga.)	0.030" (22 ga.)	0.036" (20 ga.)	0.048" (18 ga.)	0.060" (16 ga.)
42 ksi	ASTM A1008 Gr. 25	60	90	110	170	215
45 ksi	ASTM A653 Gr. 33, ASTM A1063 Gr. 33, ASTM A1008 Gr. 30	65	95	115	180	230
52 ksi	ASTM A653 Gr. 37, ASTM A1063 Gr. 37	75	115	135	210	270
55 ksi	ASTM A653 Gr. 40, ASTM A1063 Gr. 40	80	120	140	220	285
58 ksi	ASTM A36	85	125	150	230	300
65 ksi	ASTM A653 Gr. 50 Class 1, ASTM A1063 Gr. 50, ASTM A992	90	130	160	240	315
70 ksi	ASTM A653 Gr. 50 Class 3, ASTM A653 Gr. 55, ASTM A653 Gr. 60, ASTM A588	95	135	165	250	330
80 ksi	ASTM A653 Gr. 70, ASTM A1063 Gr. 70	105	140	180	270	350
90 ksi	ASTM A1063 Gr. 80	115	145	190	285	375
110 ksi	ASTM A1063 Gr. 100	140	175	225	320	415

SI: 1 in. = 25.4 mm, 1 lb. = 4.45 N

1. Steel must comply with *AISI S100*.
2. To calculate LRFD values, multiply the tabulated allowable values by 1.5.
3. Linear interpolation or extrapolation between steel tensile strengths or design steel thicknesses is permitted.
4. The steel designation is provided as an aid to designers and specifiers and is not necessarily inclusive of all possible steel types. The tabulated pull-out strength design values are applicable for any steel with the given minimum tensile strengths in the leftmost column.



5.9 SIPHD Fastener Pull-Out Strength Design Values

5.9.1 Allowable Pull-out strength values (in lb.) for SIPHD fasteners in steel are provided in Table 14.

TABLE 14. SIPHD ALLOWABLE PULL-OUT STRENGTH DESIGN VALUES (LB.)

Minimum Tensile Strength of Steel ¹	Steel Designation ⁴	Design Steel Thickness ^{2,3}					
		0.060" (16 ga.)	0.075" (14 ga.)	0.100" (12 ga.)	0.125"	0.188"	0.250"
42 ksi	ASTM A1008 Gr. 25	135	185	270	350	560	765
45 ksi	ASTM A653 Gr. 33, ASTM A1063 Gr. 33, ASTM A1008 Gr. 30	145	200	290	375	610	820
52 ksi	ASTM A653 Gr. 37, ASTM A1063 Gr. 37	165	230	335	435	735	945
55 ksi	ASTM A653 Gr. 40, ASTM A1063 Gr. 40	175	245	355	460	785	1000
58 ksi	ASTM A36	185	255	375	485	840	1055
65 ksi	ASTM A653 Gr. 50 Class 1, ASTM A1063 Gr. 50, ASTM A992	210	290	420	545	960	1180
70 ksi	ASTM A653 Gr. 50 Class 3, ASTM A653 Gr. 55, ASTM A653 Gr. 60, ASTM A588	225	310	450	585	1030	1270
80 ksi	ASTM A653 Gr. 70, ASTM A1063 Gr. 70	255	355	515	670	1140	1455
90 ksi	ASTM A1063 Gr. 80	290	395	575	755	1245	1635
110 ksi	ASTM A1063 Gr. 100	355	485	700	920	1460	2000

SI: 1 in. = 25.4 mm, 1 lb. = 4.45 N

1. Steel must comply with *AISI S100*.
2. To calculate LRFD values, multiply the tabulated allowable values by 1.5.
3. Linear interpolation or extrapolation between steel tensile strengths or design steel thicknesses is permitted.
4. The steel designation is provided as an aid to designers and specifiers and is not necessarily inclusive of all possible steel types. The tabulated pull-out strength design values are applicable for any steel with the given minimum tensile strengths in the leftmost column.



6 INSTALLATION

- 6.1 Installation shall comply with the manufacturer’s installation instructions and this TER. In the event of a conflict between the manufacturer’s installation instructions and this TER, the more restrictive shall govern.
- 6.2 Fasteners shall be installed with the appropriate rotating powered driver, per the manufacturer's instructions.
- 6.3 Fasteners shall not be struck with a hammer during installation.
- 6.4 *Installation in Wood*
 - 6.4.1 Minimum penetration is 1", unless otherwise stated in this TER.
 - 6.4.2 Lead holes are not required.
 - 6.4.3 The underside of the fastener head shall be installed flush to the surface of the wood member being connected. Fasteners shall not be overdriven.
 - 6.4.4 Minimum requirements for fastener spacing, edge distance, and end distance shall be in accordance with Table 15.

TABLE 15. SIPTP AND SIPLD MINIMUM SPACING, EDGE DISTANCE, AND END DISTANCE REQUIREMENTS IN WOOD (IN.)

Connection Geometry ^{1,2}	SIPTP & SIPLD (in.)
Edge Distance – Load in any direction	5/8
End Distance – Load parallel to grain, towards end	3 7/8
End Distance – Load parallel to grain, away from end	2 5/8
End Distance – Load perpendicular to grain	2 5/8
Spacing between Fasteners in a Row – Parallel to grain	3 7/8
Spacing between Fasteners in a Row – Perpendicular to grain	2 5/8
Spacing between Rows of Fasteners – In-line	1 1/4
Spacing between Rows of Fasteners – Staggered	5/8
SI: 1 in. = 25.4 mm 1. Edge distances, end distances, and spacing of fasteners shall be sufficient to prevent splitting of the wood or as shown in this table, whichever is the more restrictive. 2. Values for "Spacing between Rows of Fasteners-Staggered" apply where the fasteners in adjacent rows are offset by one half of the "Spacing between Fasteners in a Row"	

- 6.5 *Installation in Cold-Formed Steel*
 - 6.5.1 For installation of SIPHD fasteners in steel over 3/8" thickness, predrill with a #8 bit (0.199").
 - 6.5.2 Install using a maximum 2,000 rpm screw gun.
 - 6.5.3 Minimum requirements for fastener spacing, edge distance, and end distance shall be in accordance with Table 16.
 - 6.5.4 The fastener shall penetrate a minimum of three threads past the backside of the steel.

TABLE 16. SIPLD AND SIPHD MINIMUM SPACING, EDGE DISTANCE, AND END DISTANCE REQUIREMENTS IN COLD-FORMED STEEL (IN.)

Connection Geometry	SIPLD & SIPHD (in.)
Spacing Between Fastener	5/8
Edge Distance	3/8
End Distance	5/8
SI: 1 in. = 25.4 mm	

6.6 Installation in Concrete and Masonry (CMU Block)

- 6.6.1 For SIPTP fasteners, predrill with a 3/16" masonry bit. Install using a low rpm/high torque screw gun.
- 6.6.2 For SIPLD fasteners, predrill with a 3/16" masonry bit. Install using a maximum 2,500 rpm screw gun.
- 6.6.3 SIPTP and SIPLD shall be installed in the web of the CMU block.
- 6.6.4 Installation requirements for SIPTP and SIPLD fasteners in concrete and masonry are provided in Table 17 and Table 18.

TABLE 17. SIPTP & SIPLD INSTALLATION REQUIREMENTS IN CONCRETE (IN.)

Connection Geometry ¹	SIPTP & SIPLD (in.)
Minimum Spacing Between Fasteners	3
Critical Edge Distances (C _{ac})	3
Minimum Edge Distance (C _{min})	2 1/2
Effective Embedment (h _e)	1
Minimum Concrete Thickness	1 1/2
SI: 1 in. = 25.4 mm	
1. This information shall be used in conjunction with the requirements of Chapter 17 of ACI 318.	

TABLE 18. SIPTP & SIPLD INSTALLATION REQUIREMENTS IN CMU BLOCK (IN.)

Connection Geometry	SIPTP & SIPLD (in.)
Embedment Depth	1
Minimum Spacing	3
Minimum Edge Distance	2 1/2
SI: 1 in. = 25.4 mm	

7 TEST ENGINEERING SUBSTANTIATING DATA

- 7.1 Testing for bending yield by Structural Building Components Research Institute (SBCRI), in accordance with ASTM F1575.
- 7.2 Testing for tensile strength by SBCRI, in accordance with AISI S904.
- 7.3 Testing for shear strength by SBCRI, in accordance with AISI S904.



- 7.4 Testing for head pull-through by SBCRI, in accordance with *ASTM D1761*.
- 7.5 Testing for withdrawal by SBCRI, in accordance with *ASTM D1761*.
- 7.6 Testing for corrosion resistance by FM Approvals, in accordance with *ASTM D6294*.
- 7.7 Some information contained herein is the result of testing and/or data analysis by other sources which conform to *IBC Section 1703* and relevant [professional engineering law](#). DrJ relies on accurate data from these sources to perform engineering analysis. DrJ has reviewed and found the data provided by other professional sources to be credible.
- 7.8 Where appropriate, DrJ's analysis is based on design values that have been codified into law through codes and standards (e.g., *IBC*, *IRC*, *NDS®*, and *SDPWS*). This includes review of code provisions and any related test data that aids in comparative analysis or provides support for equivalency to an intended end-use application. Where the accuracy of design values provided herein is reliant upon the published properties of commodity materials (e.g., lumber, steel, and concrete), DrJ relies upon the grade mark, stamp, and/or design values provided by raw material suppliers to be accurate and conforming to the mechanical properties defined in the relevant material standard.

8 FINDINGS

- 8.1 When used and installed in accordance with this TER and the manufacturer's installation instructions, the product(s) listed in Section 1.1 have the reference design value properties defined herein and are approved for use in accordance with the applicable code.
- 8.2 *IBC Section 104.11* (*IRC Section R104.11* and *IFC Section 104.9* are similar) states:

104.11 Alternative materials, design and methods of construction and equipment. The provisions of this code are not intended to prevent the installation of any material or to prohibit any design or method of construction not specifically prescribed by this code, provided that any such alternative has been *approved*. An alternative material, design or method of construction shall be *approved* where the *building official* finds that the proposed design is satisfactory and complies with the intent of the provisions of this code, and that the material, method or work offered is, for the purpose intended, not less than the equivalent of that prescribed in this code...Where the alternative material, design or method of construction is not *approved*, the *building official* shall respond in writing, stating the reasons the alternative was not *approved*.

- 8.3 This product has been evaluated in the context of the codes listed in Section 2 and is compliant with all known state and local building codes. Where there are known variations in state or local codes applicable to this TER, they are listed here.
 - 8.3.1 No known variations

9 CONDITIONS OF USE

- 9.1 For SIPTP and SIPLD fasteners installed in dry lumber, the wood member must have a moisture content of less than 19 percent.
- 9.2 Use of fasteners in locations exposed to saltwater or saltwater spray is outside the scope of this evaluation report.
- 9.3 SIPTP and SIPLD fasteners installed in concrete are limited to use in uncracked normal-weight and light-weight structural concrete having a minimum specified 28 day compressive strength of 2,500 psi.
- 9.4 SIPTP and SIPLD fasteners shall not be installed in concrete where cracking has occurred or where engineering analysis shows cracking may occur.
- 9.5 SIPTP and SIPLD fasteners installed in concrete or masonry are permitted to resist static tension forces.
- 9.6 SIPTP and SIPLD fasteners installed in concrete or masonry are limited to dry use applications.
- 9.7 Periodic special inspections shall be performed in accordance with *IBC Section 1705.1.1*.



- 9.8 Where required by the *building official*, also known as the authority having jurisdiction (AHJ) in which the project is to be constructed, this TER and the installation instructions shall be submitted at the time of *permit* application.
- 9.9 Any generally accepted engineering calculations needed to show compliance with this TER shall be submitted to the AHJ for review and approval.
- 9.10 *Design loads* shall be determined in accordance with the building code adopted by the *jurisdiction* in which the project is to be constructed and/or by the Building Designer (e.g., *owner* or *registered design professional*).
- 9.11 At a minimum, this product shall be installed per Section 6 of this TER.
- 9.12 This product is manufactured under a third-party quality control program in accordance with *IBC Section 104.4* and *110.4* and *IRC Section R104.4* and *R109.2*.
- 9.13 The actual design, suitability, and use of this TER, for any particular building, is the responsibility of the *owner* or the owner's authorized agent. Therefore, the TER shall be reviewed for code compliance by the *building official* for acceptance.
- 9.14 The use of this TER is dependent on the manufacturer's in-plant QC, the ISO/IEC 17020 third-party quality assurance program and procedures, proper installation per the manufacturer's instructions, the *building official's* inspection, and any other code requirements that may apply to demonstrate and verify compliance with the applicable building code.

10 IDENTIFICATION

- 10.1 The product(s) listed in Section 1.1 are identified by a label on the board or packaging material bearing the manufacturer's name, product name, TER number, and other information to confirm code compliance.
- 10.2 Additional technical information can be found at www.trufast.com.

11 REVIEW SCHEDULE

- 11.1 This TER is subject to periodic review and revision. For the most recent version of this TER, visit drjcertification.org.
- 11.2 For information on the current status of this TER, contact [DrJ Certification](#).

