



CERTIFICATION



Approved. Sealed. Code Compliant.

Technical Evaluation Report

TER 1711-02

SkinnyBrace

Quake Bracing, LLC

Product:

SkinnyBrace

Issue Date:

September 19, 2018

Revision Date:

September 3, 2020

Subject to Renewal:

October 1, 2021





COMPANY
INFORMATION:

Quake Bracing, LLC

743 Addison St Ste A
Berkeley, CA 94710-1945

info@quakebracing.com

quakebracing.com

DIVISION: 05 00 00 - METALS

SECTION: 05 12 23 - Structural Steel for Buildings

DIVISION: 13 48 00 - Sound, Vibration, and Seismic Control

SECTION: 13 48 63 - Fabricated Seismic Control Components

1 PRODUCT EVALUATED¹

1.1 SkinnyBrace

- 1.1.1 Size A – See Section 4 for description
- 1.1.2 Size AX – See Section 4 for description
- 1.1.3 Size F – See Section 4 for description
- 1.1.4 Size FX – See Section 4 for description

2 APPLICABLE CODES AND STANDARDS^{2,3}

2.1 Codes

- 2.1.1 *CBC— 16: California Building Code*
- 2.1.2 *CRC— 16: California Residential Code*
- 2.1.3 *IBC—12, 15, 18: International Building Code®*
- 2.1.4 *IRC—12, 15, 18: International Residential Code®*

¹ Building codes require data from valid [research reports](#) be obtained from [approved sources](#). Agencies who are accredited through ISO/IEC 17065 have met the [code requirements](#) for approval by the [building official](#). DrJ is an ISO/IEC 17065 [ANAB-Accredited Product Certification Body](#) – [Accreditation #1131](#).

Through ANAB accreditation and the [IAF MLA](#), DrJ certification can be used to obtain product approval in any [jurisdiction](#) or country that has [IAF MLA Members & Signatories](#) to meet the [Purpose of the MLA](#) – “certified once, accepted everywhere.”

Building official approval of a licensed [registered design professional](#) (RDP) is performed by verifying the RDP and/or their business entity complies with all professional engineering laws of the relevant [jurisdiction](#). Therefore, the work of licensed RDPs is accepted by [building officials](#), except when plan (i.e., peer) review finds an error with respect to a specific section of the code. Where this TER is not approved, the [building official](#) responds in writing stating the reasons for [disapproval](#).

For more information on any of these topics or our mission, product evaluation policies, product approval process, and engineering law, visit drjcertification.org or call us at 608-310-6748.

² Unless otherwise noted, all references in this TER are from the 2018 version of the codes and the standards referenced therein (e.g., *ASCE 7*, *NDS*, *ASTM*). This material, design, or method of construction also complies with the 2000-2015 versions of the referenced codes and the standards referenced therein.

³ All terms defined in the applicable building codes are italicized.



2.2 Standards and Referenced Documents

- 2.2.1 ASCE 31: *Seismic Evaluation of Existing Buildings*
- 2.2.2 ASCE 41: *Seismic Rehabilitation of Existing Buildings*
- 2.2.3 ASCE/SEI 7: *Minimum Design Loads and Associated Criteria for Buildings and Other Structures*
- 2.2.4 ASTM A194: *Standard Specification for Carbon Steel, Alloy Steel, and Stainless Steel Nuts for Bolts for High Pressure or High Temperature Service, or Both*
- 2.2.5 ASTM A563: *Standard Specification for Carbon and Alloy Steel Nuts*
- 2.2.6 ASTM A572: *Standard Specification for High-Strength Low-Alloy Columbium-Vanadium Structural Steel*
- 2.2.7 ASTM A992: *Standard Specification for Structural Steel Shapes*
- 2.2.8 ASTM D7989: *Standard Practice for Demonstrating Equivalent In-Plane Lateral Seismic Performance to Wood-Frame Shear Walls Sheathed with Wood Structural Panels*
- 2.2.9 ASTM E2126: *Standard Test Methods for Cyclic (Reversed) Load Test for Shear Resistance of Vertical Elements of the Lateral Force Resisting Systems for Buildings*
- 2.2.10 ASTM F3125 – *Standard Specification for High Strength Structural Bolts, Steel and Alloy Steel, Heat Treated, 120 ksi (830 MPa) and 150 ksi (1040 MPa) Minimum Tensile Strength, Inch and Metric Dimensions*
- 2.2.11 ASTM F436: *Standard Specification for Hardened Steel Washers Inch and Metric Dimensions*
- 2.2.12 ASTM F844: *Standard Specification for Washers, Steel, Plain (Flat), Unhardened for General Use*
- 2.2.13 ASTM F959: *Standard Specification for Compressible-Washer-Type Direct Tension Indicators for Use with Structural Fasteners, Inch and Metric Series*
- 2.2.14 FEMA P-807: *Seismic Evaluation and Retrofit of Multi-Unit Wood-Frame Buildings With Weak First Stories*
- 2.2.15 SAE J429: *Mechanical and Material Requirements for Externally Threaded Fasteners*
- 2.2.16 SAE J995: *Mechanical and Material Requirements for Steel Nuts*

3 PERFORMANCE EVALUATION

3.1 SkinnyBrace was evaluated to determine the following:

- 3.1.1 Structural performance under lateral load conditions for both wind and seismic loading for use with the *IBC* performance-based provisions, [Section 2306.1](#) and [2306.3](#) for light-frame wood wall assemblies.
 - 3.1.1.1 Table 1 provides seismic design coefficients (SDC) that conform to the requirements in *ASCE 7* Section 12.2.1 and Table 12.2-1 for design of wall assemblies in buildings that require seismic design in accordance with *ASCE 7* (i.e., all seismic design categories).
 - 3.1.1.2 The basis for equivalency testing is outlined in Section 12.2.1.1 of *ASCE 7*:

Use of seismic force-resisting systems not contained in Table 12.2-1 shall be permitted contingent on submittal to and approval by The Authority Having Jurisdiction and independent structural design review of an accompanying set of design criteria and substantiating analytical and test data. The design criteria shall specify any limitations on system use, including Seismic Design Category and height; required procedures for designing the system's components and connections; required detailing; and the values of the modification coefficient, R ; overstrength factor, Ω_0 ; and deflection amplification factor, C_d .

- 3.1.1.3 The SDC evaluation uses the approach found in documentation entitled "Equivalency Characteristics and Parameters for Proprietary Shearwalls Used in Wood Framed or Cold-formed Steel Construction" using code-defined accepted engineering procedures, experience and technical judgment.
- 3.2 SkinnyBrace has been evaluated for lateral load only. Use for resisting gravity loads is outside the scope of this TER and is not approved.



- 3.3 Any code compliance issues not specifically addressed in this section are outside the scope of this TER.
- 3.4 Any Engineering evaluation conducted for this TER was performed on the dates provided in this TER and within Dr.J's professional scope of work.

4 PRODUCT DESCRIPTION AND MATERIALS

- 4.1 SkinnyBraces are assemblies of materials intended for use as lateral-force-resisting elements to resist seismic forces in buildings.
- 4.2 SkinnyBrace is made up of wide flange or other steel columns (see Item #12 in Figure 1) that include a sacrificial structural fuse () connection between the top of the column and a connection to the building framing.
 - 4.2.1 The minimum column sizes for the Size A SkinnyBrace are:
W8x35, W10x30 or HP8x36 (see Section 4.2.5)
 - 4.2.2 The minimum column sizes for the Size AX SkinnyBrace are:
W8x67 or HP10x57 (see Section 4.2.5)
 - 4.2.3 The minimum column sizes for the Size F SkinnyBrace are:
W12x65 or HP12x74 (see Section 4.2.5)
 - 4.2.4 The minimum column size for the Size FX SkinnyBrace are:
W12x136, W14x109 or W16x89 (see Section 4.2.5)
 - 4.2.5 Larger steel sections may be specified by the Engineer of Record (EOR) subject to compatibility with remaining manufactured components (see Section 5.4.3.4).
 - 4.2.6 Wide flange steel columns shall be of Type HSLA Grade 50 ($F_y = 50$ ksi) steel conforming to *ASTM A992*.
 - 4.2.7 Bearing pile (HP) steel columns shall be of Type HSLA Grade 50 ($F_y = 50$ ksi) steel conforming to *ASTM A572*.
 - 4.2.8 Structural Fuse Plates shall be of Type HSLA Grade 50 ($F_y = 50$ ksi) steel conforming to *ASTM A572*.

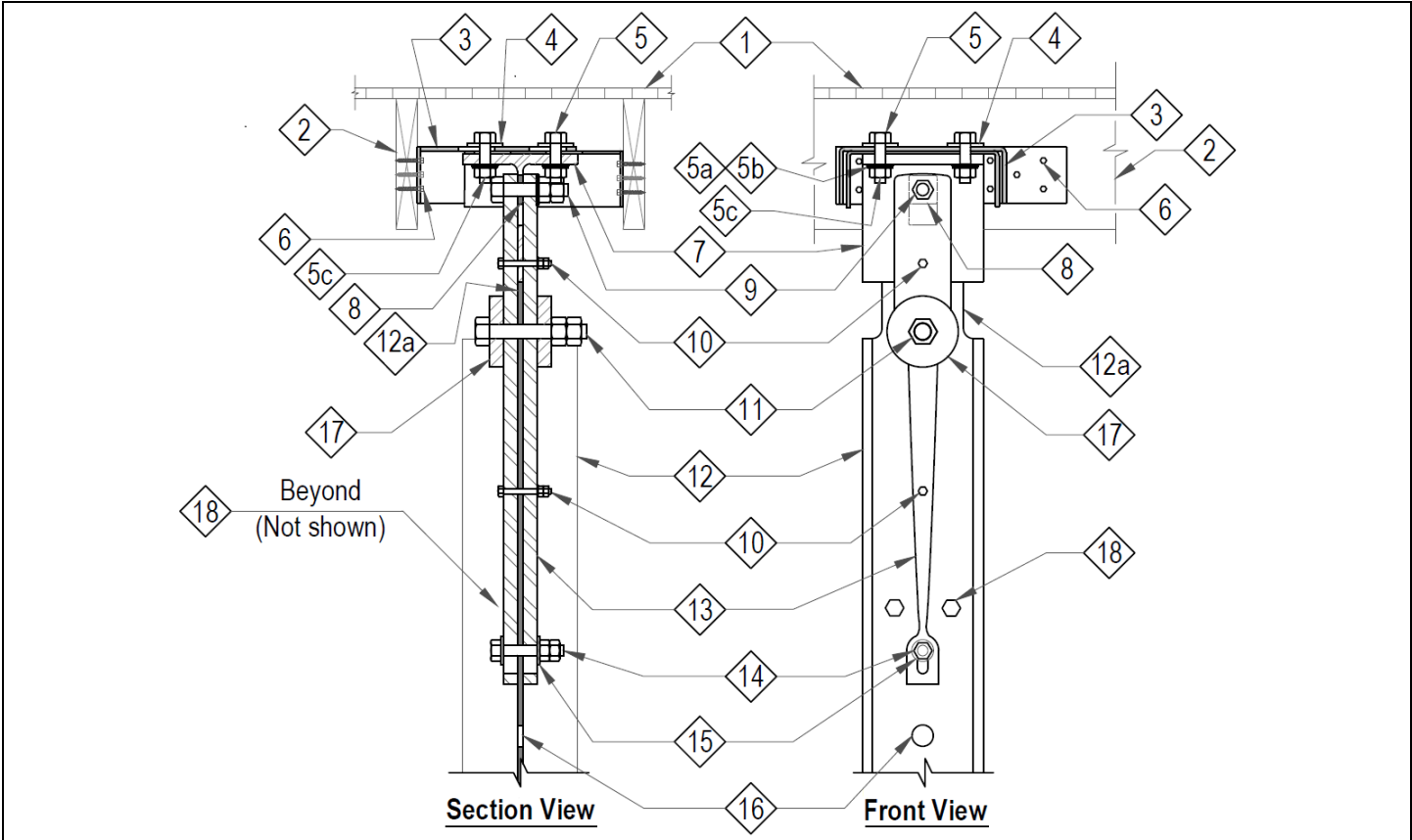

Detail of SkinnyBrace and Connections to Floor Framing

Item #	Description	Item #	Description
1	Floor Sheathing	9	Ceiling bolt through bushing and fuse plates, with double nuts
2	Floor Joists	10	Shear bolt(s), with double nuts; number, size and location varies with SkinnyBrace
3	Steel Connector Channels	11	Top bolt in column, through fuse plates, bearing plates and column web, with double nuts
4	Square Washers	12	Column
5	Connection Bolts at Loading Tee	12a	Column web extension (column web and web extension shown shaded in section view)
5a	Direct Tension Indicating Washer	13	Fuse plates both sides of column
5b	Hardened Washer	14	Bottom bolt through column web and slotted holes in fuse plates, with double nuts
5c	Hardened Nut	15	Standard round washers against fuse plates at both ends of bolt
6	Structural Screws from Connector Channels to Joist	16	Hole provided in web for utilities
7	Loading Tee	17	Bearing plate on both sides
8	Square or Rectangular Bushing (concealed between Fuse Plates)	18	Guide bolts and spacers

1. Items 7 through 18 are pre-assembled. Installer must fasten the connector channels to the building framing and the loading tee to the connector channels.

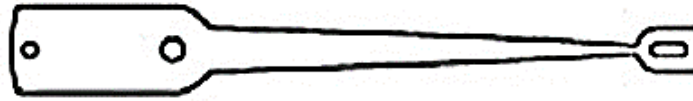

FIGURE 2. EXAMPLE OF STRUCTURAL FUSE USED IN SKINNYBRACE

FIGURE 1. SKINNYBRACE ASSEMBLY

- 4.3 The base of the column (Item #12 in Figure 1) is embedded in reinforced concrete or provided with a welded base plate to create a moment resisting connection in accordance with the detailed installation drawings.
- 4.4 SkinnyBrace is intended to provide equivalent resistance to lateral loads as compared to the existing lateral resisting system in the building.
- 4.5 A complete SkinnyBrace system includes the following:
 - 4.5.1 Column – Designed to resist lateral loads and limit deflection to an acceptable level (see Item #12 in Figure 1).
 - 4.5.2 Structural Fuses – Designed to resist lateral loads while allowing certain deflections within a specified range (see Item #13 in Figure 1).
 - 4.5.3 Shear Bolt(s) – Provide increased stiffness to the system prior to a given load level (see Item #10 in Figure 1).
 - 4.5.4 Steel Connector Channels – Connect the SkinnyBrace assembly to the existing floor system of the building above the SkinnyBrace (see Item #3 in Figure 1).
 - 4.5.5 Loading Tee – Transfers load from the Structural Fuses to the Connector Channels (see Item #7 in Figure 1) to floor system.
 - 4.5.6 Hardware and accessories shall be as follows (all items listed below are provided with the SkinnyBrace):
 - 4.5.6.1 Structural Screws – Structural wood screws for attaching the steel channel to the floor joists shall be self-drilling structural wood screws used in accordance with a current code evaluation report (see Item #6 in Figure 1).
 - 4.5.6.2 Bolts – High-strength *ASTM F3125*, Grade A325 bolts and *SAE J429*, Grade 2 and Grade 5 cap screws are used to make connections between the steel members (see Items #5, #9, #10, #11, #14, and #18 in Figure 1).
 - 4.5.6.3 Washers – Hardened washers are in accordance with *ASTM F436* (see Item #5b in Figure 1); standard round washers per *ASTM F844* (see Items #15 and #18 in Figure 1).
 - 4.5.6.4 Square Washers – $\frac{5}{16}$ " square washers are cut from steel plate (see Item #4 in Figure 1).
 - 4.5.6.5 Direct-Tension-Indicating (DTI) Washers – DTI washers shall be in accordance with *ASTM F959* (see Item #5a in Figure 1).
 - 4.5.6.6 Nuts – High-strength nuts shall be in accordance with *ASTM A563 DH* or *ASTM A194-2H* (see Item #5c in Figure 1); Standard nuts shall be in accordance with *ASTM A563A* or *SAE J995*, Grade 2 (see Items #9, #10, #11, #14, and #18 in Figure 1).
 - 4.5.6.7 Guide Bolt and Spacers – Each Guide Bolt and Spacer includes a bolt, double nut, two washers, and two custom tubular spacers (see Item #18 in Figure 1).
 - 4.5.7 SkinnyBrace is shipped with Items #7 through #18 (see Figure 1) assembled. Items #3 through #6 (see Figure 1) are provided with the SkinnyBrace to be assembled on site according to the manufacturer's written installation instructions.



5 APPLICATIONS

- 5.1 SkinnyBrace has been tested in accordance with *ASTM E2126*, Method C. Seismic design parameters and allowable loads are determined using the test data analysis methods in accordance with *ASTM D7989*.
- 5.2 The testing was conducted to measure the load capacities and drift characteristics of the SkinnyBrace as a lateral-force-resisting element with performance equivalent to wood structural panel shear walls.
- 5.3 SkinnyBrace may be used in new or existing construction.
 - 5.3.1 In existing construction, SkinnyBraces were analyzed as a replacement or supplementation for the existing lateral load resisting system of construction containing soft story irregularities.
 - 5.3.1.1 In accordance with *ASCE 7*, Section 12.3.2, soft story irregularity is defined to exist where there is a story in which the lateral stiffness is less than 70% of that in the story above or less than 80% of the average stiffness of the three stories above.
- 5.4 *Structural Applications*
 - 5.4.1 The allowable seismic lateral load capacity and seismic design coefficients for the SkinnyBrace system are as described in Table 1.

TABLE 1. ALLOWABLE SEISMIC LATERAL LOAD CAPACITY & SEISMIC DESIGN COEFFICIENTS FOR THE SKINNYBRACE SYSTEM^{1,2}

SkinnyBrace Size	Maximum Ceiling Height ³	Allowable Lateral Load Capacity (lbf) ⁴	Response Modification Coefficient R ⁵	Overstrength Factor C _d ^{6,7}	Deflection Amplification Factor C _d ⁸	Structural System Limitations & Building Height Limit (ft.)				
						Seismic Design Category				
						B	C	D	E	F
A	8' – 5 1/4"	2,400	6.5	3.0	4	NL ⁹	NL ⁹	65	65	65
AX	8' – 5 1/4"	3,400								
F	8' – 5 1/4"	8,275								
FX	8' – 5 1/4"	11,750								

SI: 1 in. = 25.4 mm, 1 lb. = 4.45 N
 2. The SkinnyBrace system shall be installed in accordance with Section 6 of this TER.
 3. All seismic design parameters follow the equivalency as defined in Section 3 of this TER.
 4. "Ceiling height" is measured from the top of the foundation grade beam, pedestal, or column base plate to the bottom of the framing members of the floor being braced with the SkinnyBrace. See Figure 3 and Figure 4 for a detail showing how the ceiling height is measured.
 5. Allowable lateral load capacity was selected to provide a minimum factor of safety of 2.5 and to meet the drift limit of 2.5% of the story height. A story height of 9 feet was used to determine the drift limit.
 6. Response modification coefficient, R, for use throughout *ASCE 7*. Note: R reduces forces to a strength level, not an allowable stress level.
 7. The tabulated value of the overstrength factor, Ω_o, is permitted to be reduced by subtracting one-half (0.5) for structures with flexible diaphragms.
 8. Collectors and their connections, bearing and anchorage of the steel column, and the lateral load path to the SkinnyBrace shall be designed in accordance with the special load combinations of *ASCE 7* Section 12.4.3.
 9. Deflection amplification factor, C_d, for use with *ASCE 7* Sections 12.8.6, 12.8.7, and 12.9.2.
 10. NL = Not Limited. Heights are measured from the base of the structure as defined in *ASCE 7* Section 11.2.

- 5.4.2 Where the application exceeds the limitations set forth herein, design shall be permitted in accordance with accepted engineering procedures, experience and technical judgment.
- 5.4.3 If an alternative steel column section is specified in accordance with Section 4.2.5 the selected section shall be designed to resist the specified lateral loads and limit deflection to an allowable level.
 - 5.4.3.1 The lateral loads shall be applied to the column at the location of the top pin connecting the fuse member to the column or an equivalent force system shall be determined to account for the moment generated by the span between the top of the column and the point of connection to the floor framing.





- 5.4.3.2 Required column strength shall be determined considering a lateral load equal to the value given in Table 1 as the Allowable Lateral Load Capacity for the SkinnyBrace size used, multiplied by the Overstrength Factor given in Table 1 (the Overstrength Factor may be reduced by 0.5 for structures with flexible diaphragms, in accordance with note 'b' in ASCE 7 Table 12.2-1). The lateral load shall be considered to act on the column as described in Section 5.4.3.1.
- 5.4.3.3 The design story drift shall be calculated using the strength level seismic forces specified in ASCE 7 Section 12.8 without reduction for allowable stress design. The allowable lateral load in Table 1 can be converted to a design strength level by dividing by 0.7.
- 5.4.3.4 Alternate column sections shall have a minimum design web thickness (t_w) and minimum clear distance between fillets at flanges (T) as listed below:
- | | | | |
|-----------|--------------|-------------------|-----------------|
| 5.4.3.4.1 | For Size A: | $t_w = 0.300$ in, | $T = 5^{3/4}$ " |
| 5.4.3.4.2 | For Size AX: | $t_w = 0.565$ in, | $T = 5^{3/4}$ " |
| 5.4.3.4.3 | For Size F: | $t_w = 0.390$ in, | $T = 9^{1/8}$ " |
| 5.4.3.4.4 | For Size FX: | $t_w = 0.525$ in, | $T = 9^{1/8}$ " |
- 5.4.3.5 For SkinnyBrace Size A, the deflection contribution of the SkinnyBrace components, other than the steel column, shall be taken as 0.277" at the design shear strength of 3,430 lbs. (2,400 lbs. / 0.7). This deflection may be reduced by the ratio of the lateral seismic force to the design shear strength. The deflection of the SkinnyBrace components shall be added to the calculated elastic deflection of the steel column at the strength level seismic forces to determine the total elastic deflection of the SkinnyBrace system. The design story drift shall be determined in accordance with ASCE 7 Section 12.8.6 using the deflection amplification factor listed in Table 1.
- 5.4.3.6 For SkinnyBrace Size AX, the deflection contribution of the SkinnyBrace components, other than the steel column, shall be taken as 0.422" at the design shear strength of 4,857 lbs. (3,400 lbs. / 0.7). This deflection may be reduced by the ratio of the lateral seismic force to the design shear strength. The deflection of the SkinnyBrace components shall be added to the calculated elastic deflection of the steel column at the strength level seismic forces to determine the total elastic deflection of the SkinnyBrace system. The design story drift shall be determined in accordance with ASCE 7 Section 12.8.6 using the deflection amplification factor listed in Table 1.
- 5.4.3.7 For SkinnyBrace Size F, the deflection contribution of the SkinnyBrace components, other than the steel column, shall be taken as 0.292" at the design shear strength of 11,821 lbs. (8,275 lbs. / 0.7). This deflection may be reduced by the ratio of the lateral seismic force to the design shear strength. The deflection of the SkinnyBrace components shall be added to the calculated elastic deflection of the steel column at the strength level seismic forces to determine the total elastic deflection of the SkinnyBrace system. The design story drift shall be determined in accordance with ASCE 7 Section 12.8.6 using the deflection amplification factor listed in Table 1.
- 5.4.3.8 For SkinnyBrace Size FX, the deflection contribution of the SkinnyBrace components, other than the steel column, shall be taken as 0.430" at the design shear strength of 16,786 lbs. (11,750 lbs. / 0.7). This deflection may be reduced by the ratio of the lateral seismic force to the design shear strength. The deflection of the SkinnyBrace components shall be added to the calculated elastic deflection of the steel column at the strength level seismic forces to determine the total elastic deflection of the SkinnyBrace system. The design story drift shall be determined in accordance with ASCE 7 Section 12.8.6 using the deflection amplification factor listed in Table 1.

* This dimension is based on the dimensions of SkinnyBrace components, and applies for all sizes of SkinnyBraces.

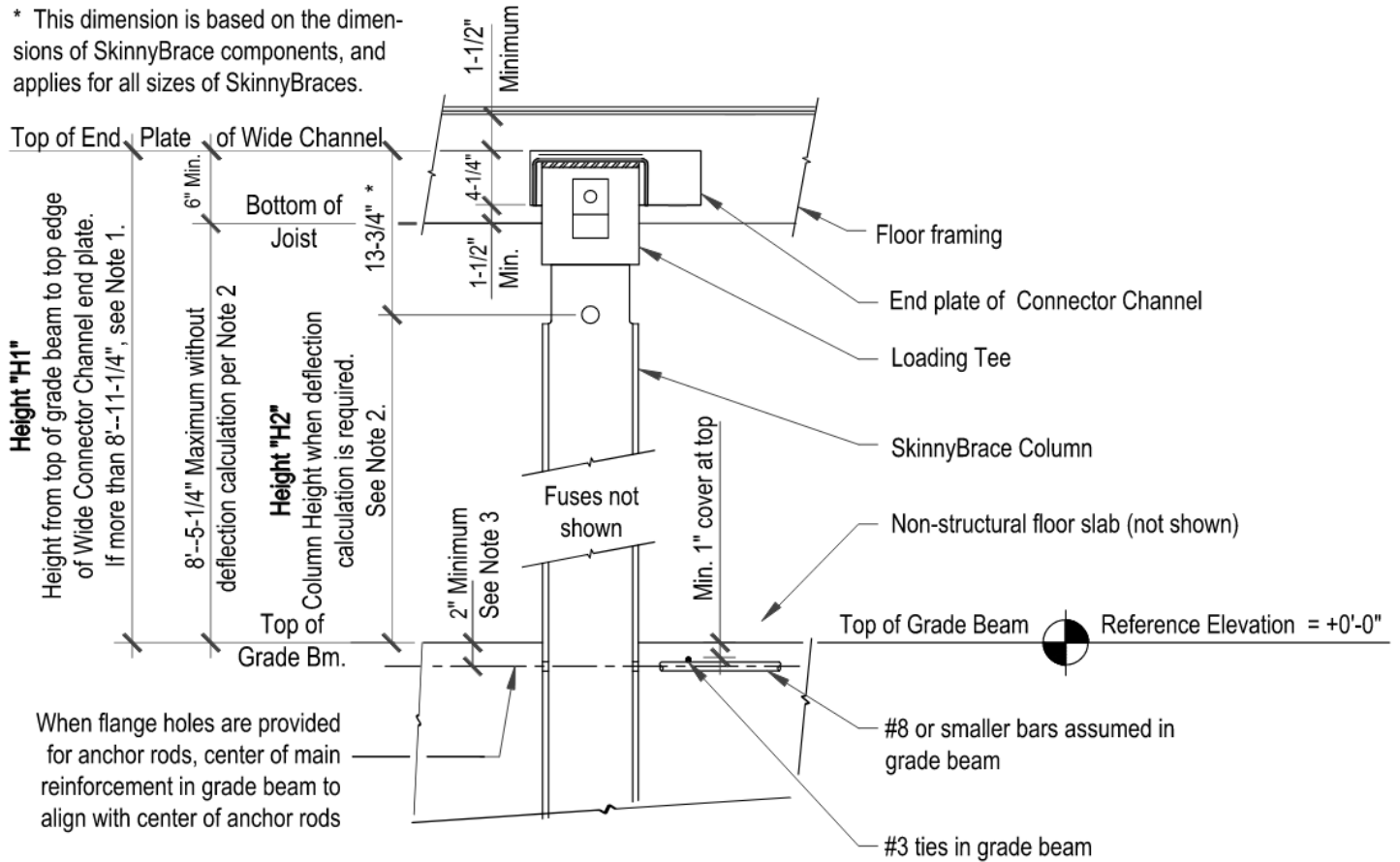

Note 1. Full tabulated values listed in Table 1 may be used if "H1" is less than 8'-11-1/4". See Section 5.3.3 for design procedure when height exceeds this limit.

Note 2. Use Height "H2" to calculate required column strength and column contribution to overall deflection per Section 5.3.3.1 when "H1" exceeds limit.

Note 3. Maximum "H1" is based on this dimension, which allows 1" concrete cover at top of grade beam, #3 seismic ties, and #8 top bars. For greater concrete cover or bar sizes, reduce "H1" correspondingly.

FIGURE 3. HEIGHT DETERMINATION FOR CONNECTION JOISTS

* This dimension is determined based on dimensions of SkinnyBrace parts

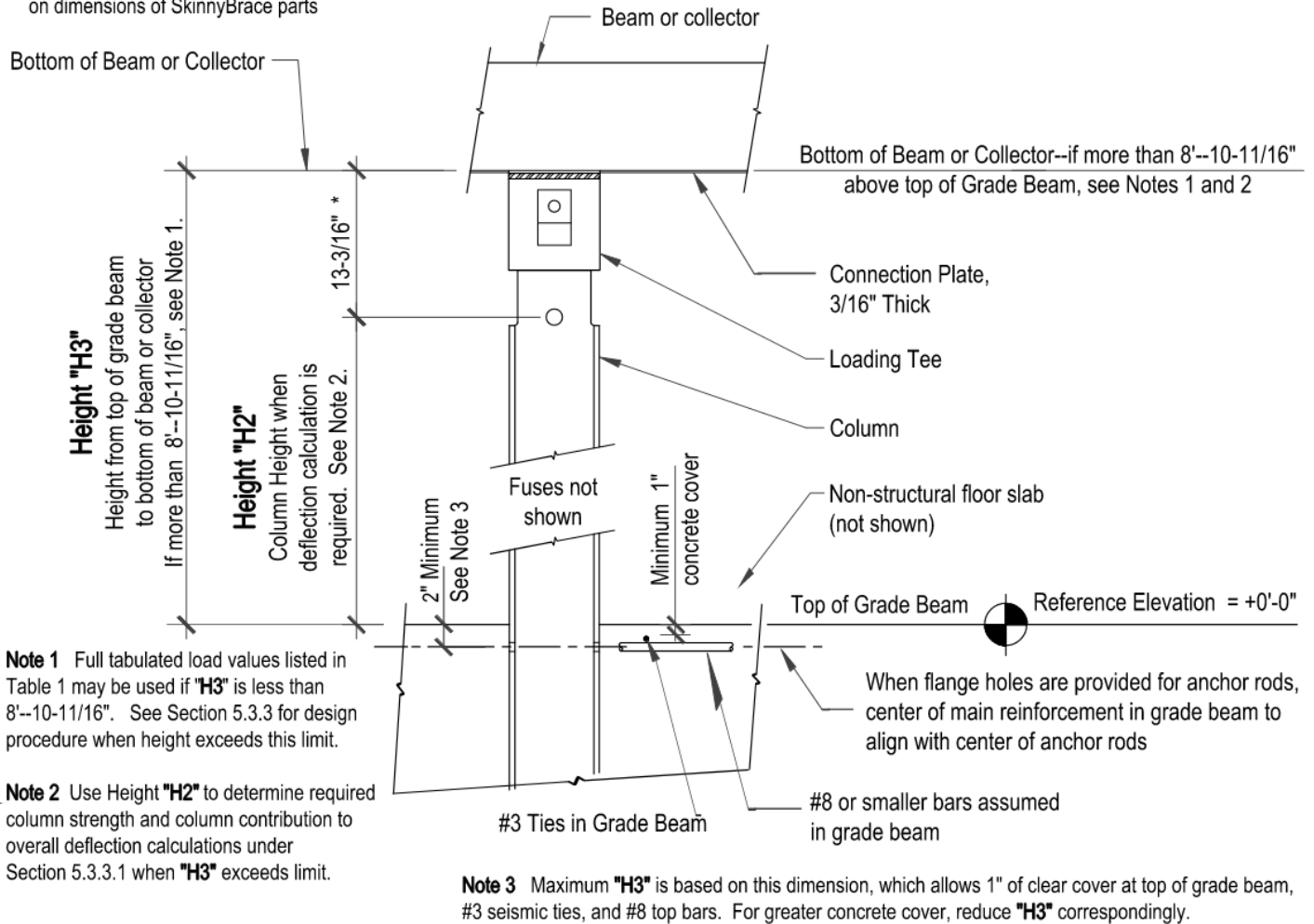

Note 1 Full tabulated load values listed in Table 1 may be used if "H3" is less than 8'-10-11/16". See Section 5.3.3 for design procedure when height exceeds this limit.

Note 2 Use Height "H2" to determine required column strength and column contribution to overall deflection calculations under Section 5.3.3.1 when "H3" exceeds limit.

Note 3 Maximum "H3" is based on this dimension, which allows 1" of clear cover at top of grade beam, #3 seismic ties, and #8 top bars. For greater concrete cover, reduce "H3" correspondingly.

FIGURE 4. HEIGHT MEASUREMENTS AT CONNECTION TO BEAM COLLECTOR

5.5 Where the application exceeds the limitations set forth herein, design shall be permitted in accordance with accepted engineering procedures, experience, and technical judgment.

6 INSTALLATION

6.1 Installation shall comply with the manufacturer's installation instructions and this TER. In the event of a conflict between the manufacturer's installation instructions and this TER, the more restrictive shall govern.

6.2 Installation Procedure

6.2.1 All SkinnyBrace installations, in new or existing construction, shall be accompanied by a complete set of detailed design drawings sealed by the registered design professional setting forth the components to be used for the installation and the requirements for installation.

6.2.1.1 When used in existing construction, consideration shall be given to the condition of the existing building and the ability to retrofit the building with the SkinnyBrace system to provide the alternate lateral load resisting system.

6.2.2 Sizing of the SkinnyBrace system components shall be such that the resistance provided exceeds the loading requirements of the building code in force in the jurisdiction where the SkinnyBrace is being installed.



- 6.2.3 The SkinnyBrace system shall also be designed to limit deflections and story drift to no more than those allowed in accordance with the adopted building code.
- 6.2.4 Collectors and their connections, bearing and anchorage of the steel column, and the lateral load path to the SkinnyBrace shall be designed in accordance with the special load combinations of *ASCE 7* Section 12.4.3.
- 6.2.5 Where connection to existing framing cannot be accomplished using the Connector Channels or Connection Plates provided by the manufacturer, the Building Designer shall design an alternative connection from the Loading Tee to the existing structure. The alternative connection shall provide for special load combinations of *ASCE 7* Section 12.4.3.

7 TEST ENGINEERING SUBSTANTIATING DATA

- 7.1 Testing for SkinnyBrace Sizes A and AX is in accordance with *ASTM E2126* using CUREE protocols by CEMCO Engineering Laboratory, November 2017.
- 7.2 Testing for SkinnyBrace Sizes F and FX is in accordance with *ASTM E2126* using CUREE protocols by Pacific Earthquake Engineering Research Center (PEER), June 2018.
- 7.3 “Structural Fuse” Connection Providing Ductility and Hysteretic Energy Dissipation with Easily Replaceable Elements to Reduce Earthquake Damage and Recovery Time, SEAOC Convention Proceedings, 2016.
- 7.4 Test data analysis in accordance with *ASTM D7989*, DrJ Engineering, 2018.
- 7.5 Some information contained herein is the result of testing and/or data analysis by other sources which conform to *IBC Section 1703*, *CBC Section 1703*, and relevant professional engineering law. DrJ relies on accurate data from these sources to perform engineering analysis. DrJ has reviewed and found the data provided by other professional sources to be credible.
- 7.6 Where appropriate, DrJ’s analysis is based on design values that have been codified into law through codes and standards (e.g., *IBC*, *IRC*, *NDS®*, and *SDPWS*). This includes review of code provisions and any related test data that aids in comparative analysis or provides support for equivalency to an intended end-use application. Where the accuracy of design values provided herein is reliant upon the published properties of commodity materials (e.g., lumber, steel, and concrete), DrJ relies upon the grade mark, stamp, and/or design values provided by raw material suppliers to be accurate and conforming to the mechanical properties defined in the relevant material standard.

8 FINDINGS

- 8.1 When used and installed in accordance with this TER and the manufacturer’s installation instructions, the product(s) listed in Section 1.1 are approved for the following:
 - 8.1.1 Quake Bracing, LLC’s SkinnyBrace system is approved to replace or supplement lateral resisting systems (i.e. wood structural panel shear walls).
 - 8.1.1.1 Approval of SkinnyBrace is based on the testing listed in Section 7, which has been submitted in accordance with *CBC Section 1703.4*.
- 8.2 *IBC Section 104.11* (*IRC Section R104.11* and *IFC Section 104.9* are similar) states:

104.11 Alternative materials, design and methods of construction and equipment. The provisions of this code are not intended to prevent the installation of any material or to prohibit any design or method of construction not specifically prescribed by this code, provided that any such alternative has been *approved*. An alternative material, design or method of construction shall be *approved* where the *building official* finds that the proposed design is satisfactory and complies with the intent of the provisions of this code, and that the material, method or work offered is, for the purpose intended, not less than the equivalent of that prescribed in this code...Where the alternative material, design or method of construction is not *approved*, the *building official* shall respond in writing, stating the reasons the alternative was not *approved*.



8.3 This product has been evaluated in the context of the codes listed in Section 2 and is compliant with all known state and local building codes. Where there are known variations in state or local codes applicable to this TER, they are listed here.

8.3.1 No known variations

9 CONDITIONS OF USE

- 9.1 Special inspection of each installed SkinnyBrace shall be conducted by a qualified third-party inspector as required by the manufacturer's installation requirements and the jurisdiction where the SkinnyBrace is installed.
- 9.2 Any generally accepted engineering calculations needed to show compliance with this TER shall be submitted to the code official for review and approval.
- 9.3 SkinnyBraces have been evaluated for lateral load only and are not approved for carrying vertical loads.
- 9.4 Where required by the building official, also known as the authority having jurisdiction (AHJ) in which the project is to be constructed, this TER and the manufacturer's installation instructions shall be submitted at the time of permit application.
- 9.5 Any generally accepted engineering calculations needed to show compliance with this TER shall be submitted to the AHJ for review and approval.
- 9.6 Design loads shall be determined in accordance with the building code adopted by the jurisdiction in which the project is to be constructed and/or by the Building Designer (e.g., owner or registered design professional).
- 9.7 At a minimum, this product shall be installed per Section 6 of this TER.
- 9.8 This product is manufactured under a third-party quality control program in accordance with IBC Section 104.4 and 110.4 and IRC Section R104.4 and R109.2.
- 9.9 The actual design, suitability, and use of this TER, for any particular building, is the responsibility of the owner or the owner's authorized agent. Therefore, the TER shall be reviewed for code compliance by the building official for acceptance.
- 9.10 The use of this TER is dependent on the manufacturer's in-plant QC, the ISO/IEC 17020 third-party quality assurance program and procedures, proper installation per the manufacturer's installation instructions, the building official's inspection, and any other code requirements that may apply to demonstrate and verify compliance with the applicable building code.

10 IDENTIFICATION

- 10.1 The product(s) listed in Section 1.1 are identified by a label on the SkinnyBrace bearing the manufacturer's name, product name, TER number, and other information to confirm code compliance.
- 10.2 Additional technical information can be found at quakebracing.com.

11 REVIEW SCHEDULE

- 11.1 This TER is subject to periodic review and revision. For the most recent version of this TER, visit drjcertification.org.
- 11.2 For information on the current status of this TER, contact DrJ Certification.