

# Listing and Technical Evaluation Report™

A Duly Authenticated Report from an Approved Agency

Report No: 1910-05



Issue Date: December 20, 2019

Revision Date: May 21, 2025

Subject to Renewal: July 1, 2026

## SPAX® 1/4" x 2" Hex Washer Head PowerLags® Fastener Steel Side Plate Application

Trade Secret Report Holder:

**Altenloh, Brinck & Company U.S., Inc.**

Phone: 419-636-6715

Website: [www.spax.us](http://www.spax.us)

### CSI Designations:

DIVISION: 06 00 00 - WOOD, PLASTICS AND COMPOSITES

Section: 06 00 90 - Wood and Plastic Fastenings

Section: 06 05 23 - Wood, Plastic, and Composite Fastenings

## 1 Innovative Product Evaluated<sup>1</sup>

- 1.1 SPAX 1/4" x 2" Hex Washer Head PowerLags (hereinafter referred to as XH250-2000 Fasteners)

## 2 Product Description and Materials

- 2.1 XH250-2000 Fasteners have a hex washer head with a 3/8" hex drive. The point is a threaded drill point.
- 2.2 The innovative product evaluated in this report is shown in **Figure 1**.

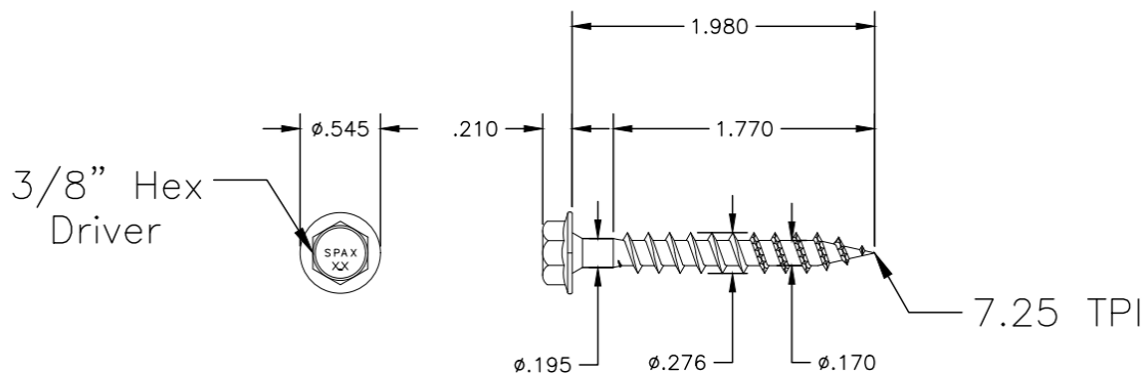

**Figure 1.** XH250-2000 Fastener

- 2.3 XH250-2000 Fasteners are made of hardened carbon steel grade 1022 or 10B21 wire conforming to ASTM A510, or grade 17MnB3 or 19MnB4 wire conforming to DIN 1654.



- 2.4 XH250-2000 Fasteners are manufactured using a standard cold-formed process, followed by heat treating and coating processes.
  - 2.4.1 XH250-2000 Fastener heads are a 3/8" hex drive.
  - 2.4.2 XH250-2000 Fasteners have a gimlet point
- 2.5 XH250-2000 Fasteners are installed without lead holes, as prescribed in NDS.
- 2.6 The innovative product evaluated in this report is outlined in **Table 1**.

**Table 1.** Fastener Designation<sup>4</sup>

Fastener	Fastener Length <sup>1</sup> (in)	Thread Length <sup>2</sup> (in)	Head (in)				Shank Diameter (in)	Diameter (in)		Bending Yield Strength, <sup>3</sup> F <sub>yb</sub> (psi)
			Style	Marking	Diameter	Height		Minor	Major	
XH250-2000 Fastener	1.980	1.770	Hex Washer	2	0.545	0.210	0.195	0.170	0.276	158,000

SI: 1 in = 25.4 mm, 1 psi = 0.00689 MPa

1. Fastener length is measured from the underside of the head to the tip.
2. Thread length includes tip (see **Figure 1**).
3. Bending yield strength, F<sub>yb</sub>, determined in accordance with ASTM F1575 using minor thread diameter when fastener is tested in threaded location.
4. Tabulated fastener dimensions are measured on uncoated fasteners. Finished dimensions are larger, due to the proprietary coatings added.

- 2.7 XH250-2000 Fasteners may be coated with a proprietary HCR™ coating system or a zinc-plate system.
  - 2.7.1 The proprietary HCR coating system exceeds the protection provided by a code approved hot-dipped galvanized coating, meeting ASTM A153 as specified in IBC Section 2304.10.6<sup>2</sup> and IRC Section R304.3.<sup>3</sup>
    - 2.7.1.1 The HCR coating is approved for use in ground contact and pressure treated wood (Alkaline Copper Quaternary Type D, also known as ACQ-D) in general construction (freshwater) applications.
    - 2.7.1.2 HCR coated fasteners are approved for use in fire-retardant treated lumber, provided the conditions set forth by the fire-retardant treated lumber manufacturer be met, including appropriate strength reductions.
  - 2.7.2 The zinc plating system provides the equivalent protection provided by a code approved hot-dipped galvanized coating meeting ASTM A153.
    - 2.7.2.1 The zinc plating system is tested and recognized for use in ground contact, pressure treated wood (ACQ-D), in dry-unexposed applications.
- 2.8 As needed, review material properties for design in **Section 6** and the regulatory evaluation in **Section 8**.

### 3 Definitions<sup>4</sup>

- 3.1 New Materials<sup>5</sup> are defined as building materials, equipment, appliances, systems, or methods of construction, not provided for by prescriptive and/or legislatively adopted regulations, known as alternative materials.<sup>6</sup> The design strength and permissible stresses shall be established by tests<sup>7</sup> and/or engineering analysis.<sup>8</sup>
- 3.2 Duly authenticated reports<sup>9</sup> and research reports<sup>10</sup> are test reports and related engineering evaluations that are written by an approved agency<sup>11</sup> and/or an approved source.<sup>12</sup>
  - 3.2.1 These reports utilize intellectual property and/or trade secrets to create public domain material properties for commercial end-use.
    - 3.2.1.1 This report protects confidential Intellectual Property and trade secrets under the regulation, 18.U.S.Code.90, also known as Defend Trade Secrets Act of 2016 (DTSA).<sup>13</sup>



- 3.3 An approved agency is “*approved*” when it is ANAB ISO/IEC 17065 accredited. DrJ Engineering, LLC (DrJ) is accredited and listed in the ANAB directory.
- 3.4 An approved source is “*approved*” when a professional engineer (i.e., Registered Design Professional, hereinafter RDP) is properly licensed to transact engineering commerce. The regulatory authority governing approved sources is the state legislature via its professional engineering regulations.<sup>14</sup>
- 3.5 Testing and/or inspections conducted for this duly authenticated report were performed by an ISO/IEC 17025 accredited testing laboratory, an ISO/IEC 17020 accredited inspection body, and/or a licensed RDP.
  - 3.5.1 The Center for Building Innovation (CBI) is ANAB<sup>15</sup> ISO/IEC 17025 and ISO/IEC 17020 accredited.
- 3.6 The regulatory authority shall enforce<sup>16</sup> the specific provisions of each legislatively adopted regulation. If there is a non-conformance, the specific regulatory section and language of the non-conformance shall be provided in writing<sup>17</sup> stating the nonconformance and the path to its cure.
- 3.7 The regulatory authority shall accept duly authenticated reports from an approved agency and/or an approved source with respect to the quality and manner of use of new materials or assemblies as provided for in regulations regarding the use of alternative materials, designs, or methods of construction.<sup>18</sup>
- 3.8 ANAB is an International Accreditation Forum (IAF) Multilateral Recognition Arrangement (MLA) signatory. Therefore, recognition of certificates and validation statements issued by conformity assessment bodies accredited by all other signatories of the IAF MLA with the appropriate scope shall be approved.<sup>19</sup> Thus, all ANAB ISO/IEC 17065 duly authenticated reports are approval equivalent,<sup>20</sup> and can be used in any country that is an MLA signatory found at this link: <https://iaf.nu/en/recognised-abs/>
- 3.9 Approval equity is a fundamental commercial and legal principle.<sup>21</sup>

#### 4 Applicable Standards for the Listing; Regulations for the Regulatory Evaluation<sup>22</sup>

##### 4.1 Standards

- 4.1.1 *ANSI/AWC NDS: National Design Specification (NDS) for Wood Construction*
- 4.1.2 *ASTM A153: Standard Specification for Zinc Coating (Hot-Dip) on Iron and Steel Hardware*
- 4.1.3 *ASTM A370: Standard Test Methods and Definitions for Mechanical Testing of Steel Products*
- 4.1.4 *ASTM B117: Standard Practice for Operating Salt Spray (Fog) Apparatus*
- 4.1.5 *ASTM D1761: Standard Test Methods for Mechanical Fasteners in Wood and Wood-Based Materials*
- 4.1.6 *ASTM F1575: Standard Test Method for Determining Bending Yield Moment of Nails*
- 4.1.7 *ASTM G85: Standard Practice for Modified Salt Spray (Fog) Testing*

##### 4.2 Regulations

- 4.2.1 *IBC – 15, 18, 21, 24: International Building Code®*
- 4.2.2 *IRC – 15, 18, 21, 24: International Residential Code®*

#### 5 Listed<sup>23</sup>

- 5.1 Equipment, materials, products, or services included in a List published by a nationally recognized testing laboratory (i.e., CBI), an approved agency (i.e., CBI and DrJ), and/or an approved source (i.e., DrJ), or other organization(s) concerned with product evaluation (i.e., DrJ), that maintains periodic inspection (i.e., CBI) of production of listed equipment or materials, and whose listing states either that the equipment or material meets nationally recognized standards or has been tested and found suitable for use in a specified manner.



## 6 Tabulated Properties Generated from Nationally Recognized Standards

6.1 XH250-2000 Fasteners are used to resist shear load parallel or perpendicular to grain when attaching steel side plates to solid sawn wood framing.

### 6.2 Lateral Design Values

6.2.1 Design of XH250-2000 Fasteners is governed by the applicable code and the provisions for dowel-type fasteners in the NDS. No further duration of load increases are permitted.

6.2.1.1 Lateral design values for XH250-2000 Fasteners installed into Douglas Fir-Larch with a steel side plate are provided in **Table 2**.

**Table 2.** Reference Lateral Design Values for Single Shear Connections in Wood with Steel Side Plate<sup>1,2</sup>

Fastener <sup>3</sup>	Main Member <sup>4</sup>	Side Member Thickness (in)	Service Condition <sup>5</sup>	Load Parallel to Grain (lbs)	Load Perpendicular to Grain (lbs)
XH250-2000 Fastener	DF-L (0.50)	1/4	Dry	425	400
			Wet	310	355
		1/8	Dry	380	385
			Wet	325	355

SI: 1 in = 25.4 mm, 1 lb = 4.45 N

- Reference lateral design values apply to two-member single shear connections where the main member is wood with a specific gravity equal to or greater than 0.50 and the side member is a steel side plate with a tensile strength ( $F_u$ ) of at least 65 ksi.
- Values shall be adjusted by all applicable factors per NDS.
- Fastener is oriented perpendicular to grain.
- The entire fastener must be embedded in the main member. The tip of the fastener shall not extend beyond the backside of the main member.
- Dry service condition is defined as lumber with an in-service moisture content of less than or equal to nineteen percent (19%). Wet service condition is defined as lumber with an in-service moisture content of greater than nineteen percent (19%).

6.3 Where the application falls outside of the performance evaluation, conditions of use, and/or installation requirements set forth herein, alternative techniques shall be permitted in accordance with accepted engineering practice and experience. This includes but is not limited to the following areas of engineering: mechanics or materials, structural, building science, and fire science.

## 7 Certified Performance<sup>24</sup>

7.1 All construction methods shall conform to accepted engineering practices to ensure durable, livable, and safe construction and shall demonstrate acceptable workmanship reflecting journeyman quality of work of the various trades.<sup>25</sup>

7.2 The strength and rigidity of the component parts and/or the integrated structure shall be determined by engineering analysis or by suitable load tests to simulate the actual loads and conditions of application that occur.<sup>26</sup>



## 8 Regulatory Evaluation and Accepted Engineering Practice

- 8.1 SPAX 1/4" x 2" Hex Washer Head PowerLags (XH250-2000 Fasteners) comply with the following legislatively adopted regulations and/or accepted engineering practice for the following reasons:
- 8.1.1 XH250-2000 Fasteners were evaluated to determine lateral design values for attaching steel side plates to wood main members in both wet and dry service conditions. The following conditions were evaluated:
    - 8.1.1.1 Bending yield in accordance with ASTM F1575
    - 8.1.1.2 Lateral resistance in accordance with ASTM D1761
    - 8.1.1.3 Corrosion resistance in accordance with ASTM B117 and ASTM G85
  - 8.1.2 Use of XH250-2000 Fasteners in locations exposed to saltwater or saltwater spray is outside the scope of this report.
  - 8.2 Any building code, regulation and/or accepted engineering evaluations (i.e., research reports, duly authenticated reports, etc.) that are conducted for this Listing were performed by DrJ, which is an ISO/IEC 17065 accredited certification body and a professional engineering company operated by RDP or approved sources. DrJ is qualified<sup>27</sup> to practice product and regulatory compliance services within its scope of accreditation and engineering expertise,<sup>28</sup> respectively.
  - 8.3 Engineering evaluations are conducted with DrJ's ANAB accredited ICS code scope of expertise, which is also its areas of professional engineering competence.
  - 8.4 Any regulation specific issues not addressed in this section are outside the scope of this report.

## 9 Installation

- 9.1 Installation shall comply with the approved construction documents, the manufacturer installation instructions, this report, and the applicable building code.
- 9.2 In the event of a conflict between the manufacturer installation instructions and this report, contact the manufacturer for counsel on the proper installation method.
- 9.3 The XH250-2000 Fasteners must be installed with a 1/2" (12.7 mm), low rpm/high torque electric drill (450 rpm) or impact wrench using the appropriate driver bit.
- 9.4 XH250-2000 Fasteners shall not be struck with a hammer during installation.
- 9.5 Lead holes are not required.
- 9.6 The bottom of the fastener head must be installed flush to the surface of the steel member being connected.
  - 9.6.1 The fastener must not be overdriven.
  - 9.6.2 In the event a fastener is overdriven, contact the manufacturer for counsel on steps to take and, if needed, a repair to be made.
- 9.7 The entire fastener must be embedded into the main member. The tip of the fastener shall not extend beyond the backside of the main member.
- 9.8 Minimum requirements for fastener spacing, edge distance, and end distance shall be in accordance with **Table 3**. See **Figure 2** for additional details.

**Table 3. Minimum Spacing, Edge Distance, and End Distance Requirements**

Connection Geometry <sup>1,2</sup>		Minimum Spacing (in)
Edge Distance – Load in any direction	(a)	1½
End Distance – Load parallel to grain, towards end	(b)	3
End Distance – Load parallel to grain, away from end	(b)	2
End Distance – Load perpendicular to grain	(c)	2
Spacing between Fasteners in a Row – Parallel to grain	(d)	3
Spacing between Fasteners in a Row – Perpendicular to grain	(e)	2
Spacing between Rows of Fasteners – In-line	(f)	1
Spacing between Rows of Fasteners – Staggered	(g)	½

SI: 1 in = 25.4 mm

- Edge distances, end distances, and spacing of fasteners shall be sufficient to prevent splitting of the wood or as shown in this table, whichever is more restrictive.
- Values for “Spacing between Rows of Fasteners-Staggered” apply where the fasteners in adjacent rows are offset by one-half of the “Spacing between Fasteners in a Row”.

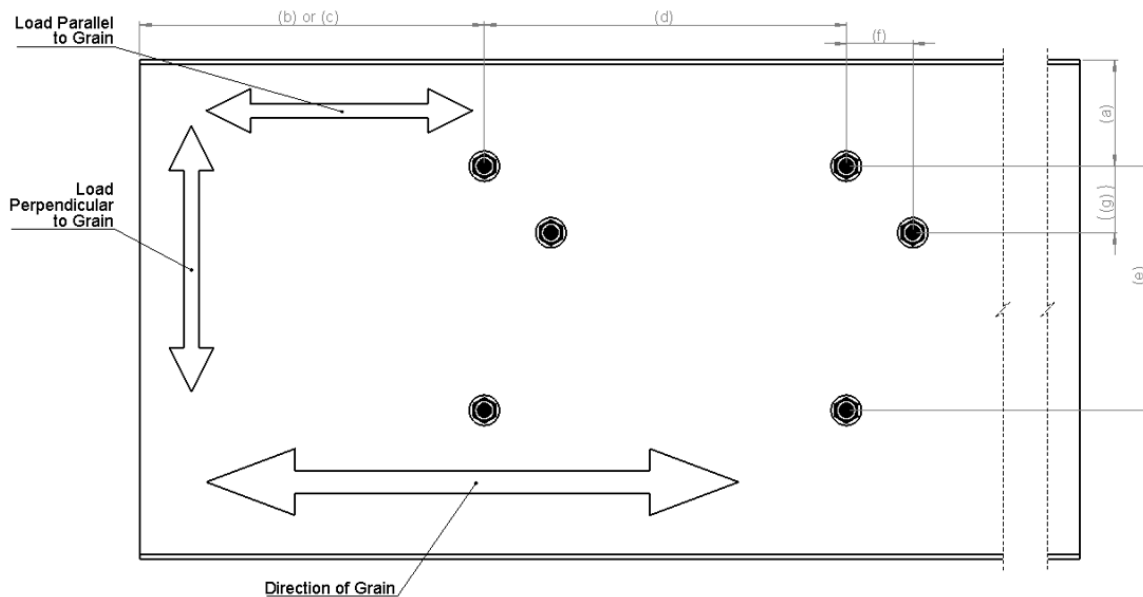

**Figure 2. XH250-2000 Fastener Spacing**





## 10 Substantiating Data

- 10.1 Testing has been performed under the supervision of a professional engineer and/or under the requirements of ISO/IEC 17025 as follows:
- 10.1.1 Testing for lateral resistance in accordance with ASTM D1761
  - 10.1.2 Testing for bending yield in accordance with ASTM F1575
  - 10.1.3 Testing for tensile strength of steel in accordance with ASTM A370
  - 10.1.4 Testing for corrosion in accordance with ASTM B117 and ASTM G85
- 10.2 Information contained herein may include the result of testing and/or data analysis by sources that are approved agencies, approved sources, and/or an RDP. Accuracy of external test data and resulting analysis is relied upon.
- 10.3 Where applicable, testing and/or engineering analysis are based upon provisions that have been codified into law through state or local adoption of regulations and standards. The developers of these regulations and standards are responsible for the reliability of published content. DrJ's engineering practice may use a regulation-adopted provision as the control. A regulation-endorsed control versus a simulation of the conditions of application to occur establishes a new material as being equivalent to the regulatory provision in terms of quality, strength, effectiveness, fire resistance, durability, and safety.
- 10.4 The accuracy of the provisions provided herein may be reliant upon the published properties of raw materials, which are defined by the grade mark, grade stamp, mill certificate, or duly authenticated reports from approved agencies and/or approved sources provided by the supplier. These are presumed to be minimum properties and relied upon to be accurate. The reliability of DrJ's engineering practice, as contained in this duly authenticated report, may be dependent upon published design properties by others.
- 10.5 *Testing and Engineering Analysis:*
- 10.5.1 The strength, rigidity, and/or general performance of component parts and/or the integrated structure are determined by suitable tests that simulate the actual conditions of application that occur and/or by accepted engineering practice and experience.<sup>29</sup>
- 10.6 Where additional condition of use and/or regulatory compliance information is required, please search for SPAX 1/4" x 2" Hex Washer Head PowerLags (XH250-2000) on the DrJ Certification website.

## 11 Findings

- 11.1 As outlined in **Section 6**, XH250-2000 Fasteners have performance characteristics that were tested and/or meet applicable regulations. In addition, they are suitable for use pursuant to its specified purpose.
- 11.2 When used and installed in accordance with this duly authenticated report and the manufacturer installation instructions, XH250-2000 Fasteners shall be approved for the following applications:
- 11.2.1 To provide resistance to lateral loads applied to the fastener in a wood main member with a steel side plate.
- 11.3 Unless exempt by state statute, when XH250-2000 Fasteners are to be used as a structural and/or building envelope component in the design of a specific building, the design shall be performed by an RDP.
- 11.4 Any application specific issues not addressed herein can be engineered by an RDP. Assistance with engineering is available from Altenloh, Brinck & Company U.S., Inc.
- 11.5 IBC Section 104.2.3 (IRC Section R104.2.2 and IFC Section 104.2.3<sup>30</sup> are similar) in pertinent part state:

**104.2.3 Alternative Materials, Design and Methods of Construction and Equipment.** The provisions of this code are not intended to prevent the installation of any material or to prohibit any design or method of construction not specifically prescribed by this code, provided that any such alternative is not specifically prohibited by this code and has been approved.



- 11.6 **Approved:**<sup>31</sup> Building regulations require that the building official shall accept duly authenticated reports.<sup>32</sup>
- 11.6.1 An approved agency is “*approved*” when it is ANAB ISO/IEC 17065 accredited.
- 11.6.2 An approved source is “*approved*” when an RDP is properly licensed to transact engineering commerce.
- 11.6.3 Federal law, Title 18 US Code Section 242, requires that, where the alternative product, material, service, design, assembly, and/or method of construction is not approved, the building official shall respond in writing, stating the reasons why the alternative was not approved. Denial without written reason deprives a protected right to free and fair competition in the marketplace.
- 11.7 DrJ is a licensed engineering company, employs licensed RDPs and is an ANAB Accredited Product Certification Body – Accreditation #1131.
- 11.8 Through the IAF Multilateral Arrangement (MLA), this duly authenticated report can be used to obtain product approval in any jurisdiction or country because all ANAB ISO/IEC 17065 duly authenticated reports are equivalent.<sup>33</sup>

## 12 Conditions of Use

- 12.1 Material properties shall not fall outside the boundaries defined in **Section 6**.
- 12.2 As defined in **Section 6**, where material and/or engineering mechanics properties are created for load resisting design purposes, the resistance to the applied load shall not exceed the ability of the defined properties to resist those loads using the principles of accepted engineering practice.
- 12.3 For XH250-2000 Fasteners installed in dry lumber, the wood member must have a moisture content of less than nineteen percent (19%).
- 12.4 Zinc-plated fasteners are approved for interior, dry use only.
- 12.5 Use of XH250-2000 Fasteners in locations exposed to saltwater or saltwater spray is outside the scope of this evaluation report.
- 12.6 When required by adopted legislation and enforced by the building official, also known as the Authority Having Jurisdiction (AHJ) in which the project is to be constructed:
- 12.6.1 Any calculations incorporated into the construction documents shall conform to accepted engineering practice and, when prepared by an approved source, shall be approved when signed and sealed.
- 12.6.2 This report and the installation instructions shall be submitted at the time of permit application.
- 12.6.3 This innovative product has an internal quality control program and a third-party quality assurance program.
- 12.6.4 At a minimum, this innovative product shall be installed per **Section 9** of this report.
- 12.6.5 The review of this report by the AHJ shall comply with IBC Section 104.2.3.2 and IBC Section 105.3.1.
- 12.6.6 This innovative product has an internal quality control program and a third party quality assurance program in accordance with IBC Section 104.7.2, IBC Section 110.4, IBC Section 1703, IRC Section R104.7.2, and IRC Section R109.2.
- 12.6.7 The application of this innovative product in the context of this report is dependent upon the accuracy of the construction documents, implementation of installation instructions, inspection as required by IBC Section 110.3, IRC Section R109.2, and any other regulatory requirements that may apply.
- 12.7 The approval of this report by the AHJ shall comply with IBC Section 1707.1, where legislation states in part, “*the building official shall make, or cause to be made, the necessary tests and investigations; or the building official shall accept duly authenticated reports from approved agencies in respect to the quality and manner of use of new materials or assemblies as provided for in Section 104.2.3*”, all of IBC Section 104, and IBC Section 105.3.





- 12.8 Design loads shall be determined in accordance with the regulations adopted by the jurisdiction in which the project is to be constructed and/or by the building designer (i.e., owner or RDP).
- 12.9 The actual design, suitability, and use of this report for any particular building, is the responsibility of the owner or the authorized agent of the owner.

### 13 Identification

- 13.1 The innovative product listed in **Section 1.1** is identified by a label on the board or packaging material bearing the manufacturer name, product name, this report number, and other information to confirm code compliance.
- 13.2 Additional technical information can be found at [www.spax.us](http://www.spax.us).

### 14 Review Schedule

- 14.1 This report is subject to periodic review and revision. For the latest version, visit [www.drjcertification.org](http://www.drjcertification.org).
- 14.2 For information on the status of this report, please contact [DrJ Certification](#).

### 15 Approved for Use Pursuant to United States and International Legislation Defined in Appendix A

- 15.1 SPAX 1/4" x 2" Hex Washer Head PowerLags (XH250-2000 Fasteners) are included in this report published by an approved agency that is concerned with evaluation of products or services, maintains periodic inspection of the production of listed materials or periodic evaluation of services. This report states either that the material, product, or service meets recognized standards or has been tested and found suitable for a specified purpose. This report meets the legislative intent and definition of being acceptable to the AHJ.



## Appendix A

### 1 Legislation that Authorizes AHJ Approval

- 1.1 **Fair Competition:** State legislatures have adopted Federal regulations for the examination and approval of building code referenced and alternative products, materials, designs, services, assemblies, and/or methods of construction that:
  - 1.1.1 Advance innovation.
  - 1.1.2 Promote competition so all businesses have the opportunity to compete on price and quality in an open market on a level playing field unhampered by anticompetitive constraints.
  - 1.1.3 Benefit consumers through lower prices, better quality, and greater choice.
- 1.2 **Adopted Legislation:** The following local, state, and federal regulations affirmatively authorize products to be approved by AHJs, delegates of building departments, and/or delegates of an agency of the federal government:
  - 1.2.1 Interstate commerce is governed by the Federal Department of Justice to encourage the use of innovative products, materials, designs, services, assemblies, and/or methods of construction. The goal is to “*protect economic freedom and opportunity by promoting free and fair competition in the marketplace*”.
  - 1.2.2 Title 18 US Code Section 242 affirms and regulates the right of individuals and businesses, to freely and fairly have new products, materials, designs, services, assemblies, and/or methods of construction approved for use in commerce. Disapproval of alternatives shall be based upon non-conformance with respect to specific provisions of adopted legislation and shall be provided in writing stating the reasons why the alternative was not approved, with reference to the specific legislation violated.
  - 1.2.3 The federal government and each state have a public records act. In addition, each state also has legislation that mimics the federal Defend Trade Secrets Act 2016 (DTSA),<sup>34</sup> where providing test reports, engineering analysis, and/or other related IP/TS is subject to prison of not more than ten years<sup>35</sup> and/or a \$5,000,000 fine or three (3) times the value of<sup>36</sup> the Intellectual Property (IP) and Trade Secrets (TS).
    - 1.2.3.1 Compliance with public records and trade secret legislation requires approval through the use of Listings, certified reports, Technical Evaluation Reports, duly authenticated reports, and/or research reports prepared by approved agencies and/or approved sources.
  - 1.2.4 For new materials<sup>37</sup> that are not specifically provided for in any regulation, the design strengths and permissible stresses shall be established by tests, where suitable load tests simulate the actual loads and conditions of application that occur.
  - 1.2.5 The design strengths and permissible stresses of any structural material shall conform to the specifications and methods of design using accepted engineering practice.<sup>38</sup>
  - 1.2.6 The commerce of approved sources (i.e., registered PEs) is regulated by professional engineering legislation. Professional engineering commerce shall always be approved by AHJs, except where there is evidence provided in writing, that specific legislation have been violated by an individual registered PE.
  - 1.2.7 The AHJ shall accept duly authenticated reports from approved agencies in respect to the quality and manner of use of new materials or assemblies as provided for in IBC Section 104.2.3.<sup>39</sup>



- 1.3 **Approved<sup>40</sup> by Los Angeles:** The Los Angeles Municipal Code (LAMC) states in pertinent part, that the provisions of LAMC are not intended to prevent the use of any material, device, or method of construction, not specifically prescribed by LAMC. The Department shall use Part III, Recognized Standards in addition to Part II, Uniform Building Code Standards of Division 35, Article 1, Chapter IX of the LAMC in evaluation of products for approval where such standard exists for the product or the material and may use other approved standards that apply. Whenever tests or certificates of any material or fabricated assembly are required by Chapter IX of the LAMC, such tests or certification shall be made by a testing agency approved by the Superintendent of Building to conduct such tests or provide such certifications. The testing agency shall publish the scope and limitation(s) of the listed material or fabricated assembly.<sup>41</sup> The Superintendent of Building Approved Testing Agency Roster is provided by the Los Angeles Department of Building and Safety (LADBS). The Center for Building Innovation (CBI) Certificate of Approval License is TA24945. Tests and certifications found in a DrJ Listing are LAMC approved. In addition, the Superintendent of Building shall accept duly authenticated reports from approved agencies in respect to the quality and manner of use of new materials or assemblies as provided for in the California Building Code, CBC Section 1707.1.<sup>42</sup>
- 1.4 **Approved by Chicago:** The Municipal Code of Chicago (MCC) states in pertinent part that an approved agency is a Nationally Recognized Testing Laboratory (NRTL) acting within its recognized scope and/or a certification body accredited by the American National Standards Institute (ANSI) acting within its accredited scope. Construction materials and test procedures shall conform to the applicable standards listed in the MCC. Sufficient technical data shall be submitted to the building official to substantiate the proposed use of any product, material, service, design, assembly, and/or method of construction, not specifically provided for in the MCC. This technical data shall consist of research reports from approved sources (i.e., MCC defined approved agencies).
- 1.5 **Approved by New York City:** The 2022 NYC Building Code (NYCBC) states in part that an approved agency shall be deemed<sup>43</sup> an approved testing agency via ISO/IEC 17025 accreditation, an approved inspection agency via ISO/IEC 17020 accreditation, and an approved product evaluation agency via ISO/IEC 17065 accreditation. Accrediting agencies, other than federal agencies, must be members of an internationally recognized cooperation of laboratory and inspection accreditation bodies subject to a mutual recognition agreement<sup>44</sup> (i.e., ANAB, International Accreditation Forum also known as IAF, etc.).
- 1.6 **Approved by Florida:** Statewide approval of products, methods, or systems of construction, shall be approved without further evaluation by:
- 1.6.1 A certification mark or listing of an approved certification agency
  - 1.6.2 A test report from an approved testing laboratory
  - 1.6.3 A product evaluation report based upon testing or comparative or rational analysis, or a combination thereof, from an approved product evaluation entity
  - 1.6.4 A product evaluation report based upon testing, comparative or rational analysis, or a combination thereof, developed, signed, and sealed by a professional engineer or architect, licensed in Florida.
  - 1.6.5 For local product approval, products or systems of construction shall demonstrate compliance with the structural wind load requirements of the Florida Building Code (FBC) through one of the following methods:
    - 1.6.5.1 A certification mark, listing, or label from a commission-approved certification agency indicating that the product complies with the code.
    - 1.6.5.2 A test report from a commission-approved testing laboratory indicating that the product tested complies with the code.
    - 1.6.5.3 A product evaluation report based upon testing, comparative or rational analysis, or a combination thereof, from a commission-approved product evaluation entity, which indicates that the product evaluated complies with the code.



- 1.6.5.4 A product evaluation report or certification based upon testing, comparative, or rational analysis, or a combination thereof, developed, signed, and sealed by a Florida professional engineer or Florida registered architect, which indicates that the product complies with the code.
- 1.6.5.5 A statewide product approval issued by the Florida Building Commission.
- 1.6.6 The [Florida Department of Business and Professional Regulation](#) (DBPR) website provides a listing of companies certified as a [Product Evaluation Agency](#) (i.e., EVLMiami 13692), a [Product Certification Agency](#) (i.e., CER10642), and as a [Florida Registered Engineer](#) (i.e., ANE13741).
- 1.7 **Approved by Miami-Dade County (i.e., Notice of Acceptance [NOA]):** A Florida statewide approval is an NOA. An NOA is a Florida local product approval. By Florida law, Miami-Dade County shall accept the statewide and local Florida Product Approval as provided for in Florida legislation [553.842](#) and [553.8425](#).
- 1.8 **Approved by New Jersey:** Pursuant to the 2018 Building Code of New Jersey in [IBC Section 1707.1 General](#),<sup>45</sup> it states: *"In the absence of approved rules or other approved standards, the building official shall accept duly authenticated reports from [approved agencies](#) in respect to the quality and manner of use of new materials or assemblies as provided for in the administrative provisions of the Uniform Construction Code (N.J.A.C. 5:23)".*<sup>46</sup> Furthermore N.J.A.C 5:23-3.7 states: *"Municipal approvals of alternative materials, equipment, or methods of construction"*.
  - 1.8.1 **Approvals:** Alternative materials, equipment, or methods of construction shall be approved by the appropriate subcode official, provided the proposed design is satisfactory and that the materials, equipment, or methods of construction are suitable for the intended use and are at least the equivalent in quality, strength, effectiveness, fire resistance, durability, and safety of those conforming with the requirements of the regulations.
    - 1.8.1.1 A field evaluation label and report or letter issued by a nationally recognized testing laboratory verifying that the specific material, equipment, or method of construction meets the identified standards or has been tested and found to be suitable for the intended use, shall be accepted by the appropriate subcode official as meeting the requirements of the above.
    - 1.8.1.2 Reports of engineering findings issued by nationally recognized evaluation service programs such as, but not limited to, the Building Officials and Code Administrators (BOCA), the International Conference of Building Officials (ICBO), the Southern Building Code Congress International (SBCCI), the International Code Council (ICC), and the National Evaluation Service, Inc., shall be accepted by the appropriate subcode official as meeting the requirements of the above.
  - 1.8.2 The [New Jersey Department of Community Affairs](#) has confirmed that technical evaluation reports, from any accredited entity listed by [ANAB](#), meets the requirements of item the previous paragraph, given that the listed entities are no longer in existence and/or do not provide *"reports of engineering findings"*.
- 1.9 **Approved by the Code of Federal Regulations Manufactured Home Construction and Safety Standards:** Pursuant to Title 24, Subtitle B, Chapter XX, [Part 3282.14](#)<sup>47</sup> and [Part 3280](#),<sup>48</sup> the Department encourages innovation and the use of new technology in manufactured homes. The design and construction of a manufactured home shall conform to the provisions of Part 3282 and Part 3280 where key approval provisions in mandatory language follow:
  - 1.9.1 *"All construction methods shall be in conformance with accepted engineering practices."*
  - 1.9.2 *"The strength and rigidity of the component parts and/or the integrated structure shall be determined by engineering analysis or by suitable load tests to simulate the actual loads and conditions of application that occur."*
  - 1.9.3 *"The design stresses of all materials shall conform to accepted engineering practice."*



- 1.10 **Approval by US, Local, and State Jurisdictions in General:** In all other local and state jurisdictions, the adopted building code legislation states in pertinent part that:
- 1.10.1 For new materials that are not specifically provided for in this code, the design strengths and permissible stresses shall be established by tests.<sup>49</sup>
  - 1.10.2 For innovative alternatives and/or methods of construction, the building official shall accept duly authenticated reports from approved agencies with respect to the quality and manner of use of new materials or assemblies.<sup>50</sup>
    - 1.10.2.1 An approved agency is “*approved*” when it is ANAB ISO/IEC 17065 accredited. DrJ is in the ANAB directory.
    - 1.10.2.2 An approved source is “*approved*” when an RDP is properly licensed to transact engineering commerce. The regulatory authority governing approved sources is the state legislature via its professional engineering regulations.<sup>51</sup>
  - 1.10.3 The design strengths and permissible stresses of any structural material...shall conform to the specifications and methods of design of accepted engineering practice performed by an approved source.<sup>52</sup>
- 1.11 **Approval by International Jurisdictions:** The USMCA and GATT agreements provide for approval of innovative materials, designs, services, and/or methods of construction through the Agreement on Technical Barriers to Trade and the IAF Multilateral Recognition Arrangement (MLA), where these agreements:
- 1.11.1 State that conformity assessment procedures (i.e., ISO/IEC 17020, 17025, 17065, etc.) are prepared, adopted, and applied so as to grant access for suppliers of like products originating in the territories of other Members under conditions no less favourable than those accorded to suppliers of like products of national origin or originating in any other country, in a comparable situation.
  - 1.11.2 **Approved:** The purpose of the MLA is to ensure mutual recognition of accredited certification and validation/verification statements between signatories to the MLA and subsequently, acceptance of accredited certification and validation/verification statements in many markets based on one accreditation for the timely approval of innovative materials, designs, services, and/or methods of construction.
  - 1.11.3 ANAB is an IAF MLA signatory where recognition of certificates, validation, and verification statements issued by conformity assessment bodies accredited by all other signatories of the IAF MLA, with the appropriate scope, shall be approved.<sup>53</sup>
  - 1.11.4 Therefore, all ANAB ISO/IEC 17065 duly authenticated reports are approval equivalent.<sup>54</sup>
- 1.12 Approval equity is a fundamental commercial and legal principle.<sup>55</sup>





# Notes

1 For more information, visit [drjcertification.org](http://drjcertification.org) or call us at 608-310-6748.

2 [2018 IBC Section 2304.10.5](#)

3 [2021 IRC Section R317.3](#)

4 Capitalized terms and responsibilities are defined pursuant to the applicable building code, applicable reference standards, the latest edition of [TPI 1](#), the [NDS](#), [AISI S202](#), [US professional engineering law](#), [Canadian building code](#), [Canada professional engineering law](#), [Qualtim External Appendix A: Definitions/Commentary](#), [Qualtim External Appendix B: Project/Deliverables](#), [Qualtim External Appendix C: Intellectual Property and Trade Secrets](#), definitions created within Design Drawings and/or definitions within Reference Sheets. Beyond this, terms not defined shall have ordinarily accepted meanings as the context implies. Words used in the present tense include the future; words stated in the masculine gender include the feminine and neuter; the singular number includes the plural and the plural, the singular.

5 <https://up.codes/viewer/mississippi/ibc-2024/chapter/17/special-inspections-and-tests#1702>

6 Alternative Materials, Design and Methods of Construction and Equipment: The provisions of any regulation code are not intended to prevent the installation of any material or to prohibit any design or method of construction not specifically prescribed by a regulation. Please review <https://www.justice.gov/atr/mission> and <https://up.codes/viewer/mississippi/ibc-2024/chapter/1/scope-and-administration#104.2.3>

7 <https://up.codes/viewer/mississippi/ibc-2024/chapter/17/special-inspections-and-tests#1706.2>:-:text=the%20design%20strengths%20and%20permissible%20stresses%20shall%20be%20established%20by%20tests

8 The [design strengths](#) and permissible stresses of any structural material shall conform to the specifications and methods of design of accepted engineering practice. <https://up.codes/viewer/mississippi/ibc-2024/chapter/17/special-inspections-and-tests#1706.1>:-:text=Conformance%20to%20Standards-.The%20design%20strengths%20and%20permissible%20stresses,-of%20any%20structural

9 <https://up.codes/viewer/mississippi/ibc-2024/chapter/17/special-inspections-and-tests#1707.1>:-:text=the%20building%20official%20shall%20make%20or%20cause%20to%20be%20made%20the%20necessary%20tests%20and%20investigations%20or%20the%20building%20official%20shall%20accept%20duly%20authenticated%20reports%20from%20approved%20agencies%20in%20respect%20to%20the%20quality%20and%20manner%20of%20use%20of%20new%20materials%20or%20assemblies%20as%20provided%20for%20in%20Section%20104.2.3.

10 <https://up.codes/viewer/mississippi/ibc-2024/chapter/17/special-inspections-and-tests#1703.4.2>

11 [https://up.codes/viewer/mississippi/ibc-2024/chapter/2/definitions#approved\\_agency](https://up.codes/viewer/mississippi/ibc-2024/chapter/2/definitions#approved_agency)

12 [https://up.codes/viewer/mississippi/ibc-2024/chapter/2/definitions#approved\\_source](https://up.codes/viewer/mississippi/ibc-2024/chapter/2/definitions#approved_source)

13 <https://www.law.cornell.edu/uscode/text/18/1832> (b) Any organization that commits any offense described in subsection (a) shall be fined not more than the greater of \$5,000,000 or 3 times the value of the stolen trade secret to the organization, including expenses for research and design and other costs of reproducing the trade secret that the organization has thereby avoided. The federal government and each state have a [public records act](#). To follow DTSA and comply state public records and trade secret legislation requires approval through ANAB ISO/IEC 17065 accredited certification bodies or approved sources. For more information, please review this website: [Intellectual Property and Trade Secrets](#).

14 <https://www.nspe.org/resources/issues-and-advocacy/professional-policies-and-position-statements/regulation-professional> AND <https://apassociation.org/list-of-engineering-boards-in-each-state-archive/>

15 <https://www.cbiteest.com/accreditation/>

16 <https://up.codes/viewer/mississippi/ibc-2024/chapter/1/scope-and-administration#104.1>:-:text=directed%20to%20enforce%20the%20provisions%20of%20this%20code

17 <https://up.codes/viewer/mississippi/ibc-2024/chapter/1/scope-and-administration#104.2.3> AND <https://up.codes/viewer/mississippi/ibc-2024/chapter/1/scope-and-administration#105.3.1>

18 <https://up.codes/viewer/mississippi/ibc-2024/chapter/17/special-inspections-and-tests#1707.1>

19 <https://iaf.nu/en/about-iaf-mia/#>:-:text=Once%20an%20accreditation%20body%20is%20a%20signatory%20of%20the%20IAF%20MLA%20it%20is%20required%20to%20recognise%20certificates%20and%20validation%20and%20verification%20statements%20issued%20by%20conformity%20assessment%20bodies%20accredited%20by%20all%20other%20signatories%20of%20the%20IAF%20MLA%20with%20the%20appropriate%20scope

20 True for all ANAB accredited product evaluation agencies and all International Trade Agreements.

21 <https://www.justice.gov/crt/deprivation-rights-under-color-law> AND <https://www.justice.gov/atr/mission>

22 Unless otherwise noted, the links referenced herein use un-amended versions of the [2024 International Code Council \(ICC\) 2024 International Code Council \(ICC\) model codes](#) as foundation references. Mississippi versions of the [IBC 2024](#) and the [IRC 2024](#) are un-amended. This material, product, design, service and/or method of construction also complies with the 2000-2012 versions of the referenced codes and the standards referenced therein. As pertinent to this technical and code compliance evaluation, CBI and/or DrJ staff have reviewed any state or local regulatory amendments to assure this report is in compliance.

23 <https://www.ecfr.gov/current/title-24/subtitle-B/chapter-XX/part-3280#p-3280.2>(Listed%20or%20certified); <https://up.codes/viewer/mississippi/ibc-2024/chapter/2/definitions#listed> AND <https://up.codes/viewer/mississippi/ibc-2024/chapter/2/definitions#labeled>

24 <https://up.codes/viewer/mississippi/ibc-2024/chapter/17/special-inspections-and-tests#1703.4>

25 <https://www.ecfr.gov/current/title-24/subtitle-B/chapter-XX/part-3280#>:-:text=All%20construction%20methods%20shall%20be%20in%20conformance%20with%20accepted%20engineering%20practices%20to%20insure%20durable%20livable%20and%20safe%20housing%20and%20shall%20demonstrate%20acceptable%20workmanship%20reflecting%20journeyman%20quality%20of%20work%20of%20the%20various%20trades

26 <https://www.ecfr.gov/current/title-24/subtitle-B/chapter-XX/part-3280#>:-:text=The%20strength%20and%20rigidity%20of%20the%20component%20parts%20and/or%20the%20integrated%20structure%20shall%20be%20determined%20by%20engineering%20analysis%20or%20by%20suitable%20load%20tests%20to%20simulate%20the%20actual%20loads%20and%20conditions%20of%20application%20that%20occur

27 Qualification is performed by a legislatively defined [Accreditation Body](#). [ANSI National Accreditation Board \(ANAB\)](#) is the largest independent accreditation body in North America and provides services in more than 75 countries. [DrJ](#) is an ANAB accredited [product certification body](#).

28 <https://anabpd.ansi.org/Accreditation/product-certification/AllDirectoryDetails?prqID=1&orgID=2125&statusID=4#>:-:text=Bill%20Payment%20Date,-Accredited%20Scopes,-13%20ENVIRONMENT.%20HEALTH





29 See Code of Federal Regulations (CFR) Title 24 Subtitle B Chapter XX Part 3280 for definition: <https://www.ecfr.gov/current/title-24/subtitle-B/chapter-XX/part-3280>

30 2018: <https://up.codes/viewer/wyoming/ifc-2018/chapter/1/scope-and-administration#104.9> AND 2021: <https://up.codes/viewer/wyoming/ibc-2021/chapter/1/scope-and-administration#104.11>

31 Approved is an adjective that modifies the noun after it. For example, Approved Agency means that the Agency is accepted officially as being suitable in a particular situation. This example conforms to IBC/IRC/IFC Section 201.4 (<https://up.codes/viewer/mississippi/ibc-2024/chapter/2/definitions#201.4>) where the building code authorizes sentences to have an ordinarily accepted meaning such as the context implies.

32 <https://up.codes/viewer/mississippi/ibc-2024/chapter/17/special-inspections-and-tests#1707.1>

33 Multilateral approval is true for all ANAB accredited product evaluation agencies and all International Trade Agreements.

34 <http://www.drjengineering.org/AppendixC> AND <https://www.law.cornell.edu/uscode/text/18/part-11/chapter-90>

35 <https://www.law.cornell.edu/uscode/text/18/1832#:~:text=imprisoned%20not%20more%20than%2010%20years>

36 <https://www.law.cornell.edu/uscode/text/18/1832#:~:text=Any%20organization%20that,has%20thereby%20avoided>

37 <https://up.codes/viewer/mississippi/ibc-2024/chapter/17/special-inspections-and-tests#1706.2>

38 IBC 2024, Section 1706.1 Conformance to Standards

39 IBC 2024, Section 1707 Alternative Test Procedure, 1707.1 General

40 See Section 11 for the distilled building code definition of **Approved**.

41 Los Angeles Municipal Code, SEC. 98.0503. TESTING AGENCIES

42 <https://up.codes/viewer/california/ca-building-code-2022/chapter/17/special-inspections-and-tests#1707.1>

43 New York City, The Rules of the City of New York, § 101-07 Approved Agencies

44 New York City, The Rules of the City of New York, § 101-07 Approved Agencies

45 2018: [https://up.codes/viewer/new\\_jersey/ibc-2018/chapter/17/special-inspections-and-tests#1707.1](https://up.codes/viewer/new_jersey/ibc-2018/chapter/17/special-inspections-and-tests#1707.1) AND 2021: [https://up.codes/viewer/new\\_jersey/ibc-2021/chapter/17/special-inspections-and-tests#1707.1](https://up.codes/viewer/new_jersey/ibc-2021/chapter/17/special-inspections-and-tests#1707.1)

46 <https://www.nj.gov/dca/divisions/codes/codreg/ucc.html>

47 <https://www.ecfr.gov/current/title-24/section-3282.14>

48 <https://www.ecfr.gov/current/title-24/part-3280>

49 2024 IBC Section 1706 Design Strengths of Materials (<https://up.codes/viewer/mississippi/ibc-2024/chapter/17/special-inspections-and-tests#1706>) AND 2024 IBC Section 1706.2 New Materials (<https://up.codes/viewer/mississippi/ibc-2024/chapter/17/special-inspections-and-tests#1706.2>) Adopted law pursuant to IBC model code language 1706.2.

50 IBC 2024, Section 1707 Alternative Test Procedure, 1707.1 General (<https://up.codes/viewer/mississippi/ibc-2024/chapter/17/special-inspections-and-tests#1707.1>) Adopted law pursuant to IBC model code language 1707.1.

51 <https://www.nspe.org/resources/issues-and-advocacy/professional-policies-and-position-statements/regulation-professional> AND <https://apassociation.org/list-of-engineering-boards-in-each-state-archive/>

52 IBC 2024, Section 1706 Design Strengths of Materials and IBC 2024 Section 1706.1 Conformance to Standards Adopted law pursuant to IBC model code language 1706.1.

53 IAF MLA: <https://iaf.nu/en/about-iaf-mla/#:~:text=Once%20an%20accreditation%20body%20is%20a%20signatory%20of%20the%20IAF%20MLA%2C%20it%20is%20required%20to%20recognise%20certificates%20and%20validation%20and%20verification%20statements%20issued%20by%20conformity%20assessment%20bodies%20accredited%20by%20all%20other%20signatories%20of%20the%20IAF%20MLA%2C%20with%20the%20appropriate%20scope>

54 True for all ANAB accredited product evaluation agencies and all International Trade Agreements.

55 <https://www.justice.gov/crt/deprivation-rights-under-color-law> AND <https://www.justice.gov/atr/mission>