

Listing and Technical Evaluation Report™

A Duly Authenticated Report from an Approved Agency

Report No: 1506-20



Issue Date: July 8, 2015

Revision Date: March 11, 2026

Subject to Renewal: April 1, 2027

QuickTie™ System Portal Frame with Hold-Downs

Trade Secret Report Holder:
QuickTie™ Products, Inc.

Phone: 940-281-0525

Website: quicktieproducts.com

CSI Designations:

DIVISION: 06 00 00 - WOOD, PLASTICS AND COMPOSITES

Section: 06 00 90 - Wood and Plastic Fastenings

1 Innovative Products Evaluated¹

1.1 QuickTie System (QTS) Portal Frame with Hold-Downs (PFH)

2 Product Description and Materials

2.1 The innovative products evaluated in this report are shown in **Figure 1** and **Figure 2**.

2.1.1 *QTB(L) Blue (3/16" aircraft wire rope):* 3/16" diameter, 7 x 19, hot-dipped galvanized steel wire with a minimum nominal strength of 4,200 lbs per ASTM A1023. Individual wires in the wire rope are galvanized with a minimum of 0.10 ounces per square foot of uncoated wire surface (see **Figure 1**).

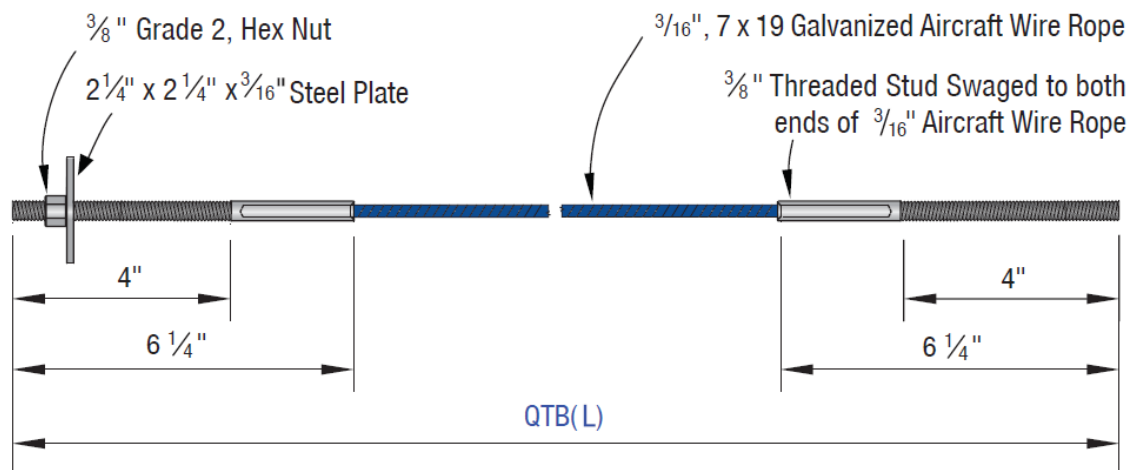

Figure 1. QuickTie Part Detail – QTB(L) Blue 3/16" Diameter

2.1.2 **QTO(L) Orange ($\frac{5}{16}$ " aircraft wire rope):** $\frac{5}{16}$ " diameter, 7 x 19, hot-dipped galvanized steel wire with a minimum nominal strength of 9,800 lbs per ASTM A1023. Individual wires in the wire rope are galvanized with a minimum of 0.10 ounces per square foot of uncoated wire surface (see **Figure 2**).

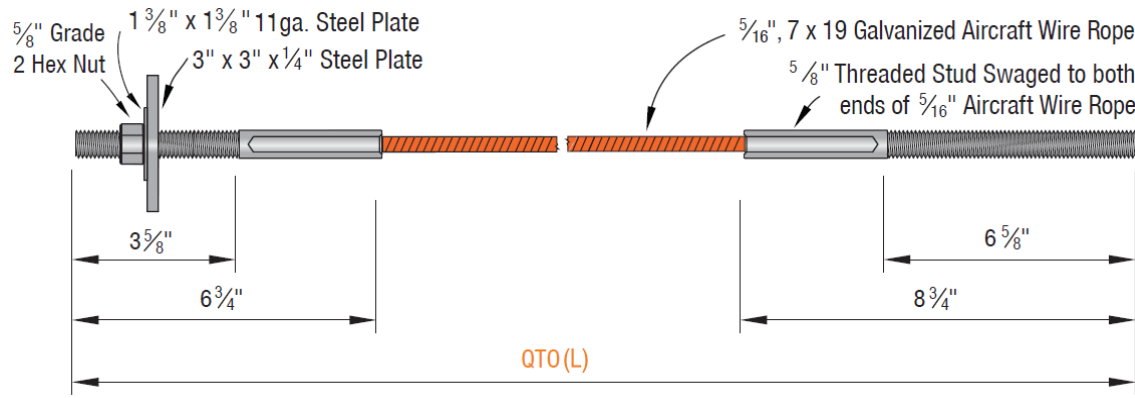

Figure 2. QuickTie Part Detail – QTO(L) Orange $\frac{5}{16}$ " Diameter

2.2 QTS Description

2.2.1 The QTS is a wall anchoring system for conventional light-frame construction and masonry projects that involve a Registered Design Professional (RDP).

2.2.2 The QTS provides a continuous load path from the top of the wall to the foundation by resisting and transferring wind uplift and/or laterally applied loads that result in overturning uplift forces.

2.2.3 The QTS consists of a galvanized aircraft wire rope (cable) with threaded studs swaged to each end.

2.2.4 Portal Frames with Hold-Down (PFH) – Primary Connection:

2.2.4.1 QuickTie cables with threaded bottoms will be connected to the foundation via an embedded anchor bolt cast in place. The QuickTie cable will be attached to the anchor bolt by a mechanical coupling.

2.2.4.2 The other threaded stud is extended vertically within the interior wood stud wall to the top of the wall, inserted through a hole drilled through the wood top plate(s) and attached to a steel plate and nut placed on the top surface of the topmost plate on the wall. The nut is then tightened to post tension the QTS.

2.2.5 Alternative Connection:

2.2.5.1 The end of the QuickTie cable with longer threads and no plate washers will be connected to the foundation via a formed or drilled hole in the foundation. The hole is filled with epoxy and the QuickTie cable is inserted into the hole and left to set.

2.2.5.2 The other threaded stud is extended vertically within the interior wood stud wall to the top of the wall, inserted through a hole drilled through the wood top plate(s) and attached to a steel plate and nut placed on the top surface of the topmost plate on the wall. The nut is then tightened to post tension the QTS.

2.2.5.3 Approved Epoxy Products for Use with QTS:

2.2.5.3.1 QuickTie QE-1 and QuickTie QE-2:

2.2.5.3.1.1 QE-1 and QE-2 epoxy adhesives are an injectable, two-component adhesive for use in both cracked and uncracked normal-weight concrete applications.

2.2.5.3.1.2 QE-1 and QE-2 epoxy adhesives may be used for various anchoring systems, including QuickTie System (the threaded rod anchors), and deformed reinforcing bars (rebar).

- 2.2.5.3.1.3 QE-1 and QE-2 epoxy adhesives and associated accessories are shown in **Figure 3**.
- 2.2.5.3.1.4 See code reports for QE-1 and QE-2, and/or contact the manufacturer for additional details.



Figure 3. QuickTie Epoxy Adhesive Products and Accessories

- 2.2.6 Trusses, headers and bottom plates are connected with Quick Connectors to provide distribution of load through the QTS to the foundation.
- 2.2.7 Where one QuickTie cable does not provide sufficient capacity, multiple cables of the same type may be installed to increase the pre-stressing force and transfer of accumulated loads to the foundation.
- 2.3 *QuickTie System Materials*
 - 2.3.1 *QuickTie QT(L) Wood Frame Connectors (note that the "L" indicates length in feet):* galvanized aircraft wire rope, $\frac{3}{16}$ " diameter, $\frac{5}{16}$ " diameter. Threaded studs in the following sizes are swaged onto each end of the wire rope:
 - 2.3.1.1 Individual wires are 0.030" diameter or smaller, with minimum $F_u = 268,000$ -psi. The length varies in 1" increments from 2' to 60'.
 - 2.3.2 *Steel Plate Washers:*
 - 2.3.2.1 Washers are made from the following materials:
 - 2.3.2.1.1 *QTB(L) Blue $\frac{3}{16}$ " diameter wire rope:* $2\frac{1}{4}$ " x $2\frac{1}{4}$ " x $\frac{3}{16}$ " ASTM A36, A283/284 or A570 steel plate, with a minimum yield strength of 33-ksi and a minimum ultimate strength of 45-ksi.
 - 2.3.2.1.2 *QTO(L) Orange $\frac{5}{16}$ " diameter wire rope:* 3 " x 3 " x $\frac{1}{4}$ " ASTM A36, A283/284 or A570 steel plates, with a minimum yield strength of 33-ksi and a minimum ultimate strength of 45-ksi.



2.3.3 Tension Indicator Device:

2.3.3.1 Tension Indicator Devices (TID) are made from the following materials:

2.3.3.1.1 *Blue*: ASTM A653, Grade 33 structural steel, 14-gauge, minimum thickness 0.0821", painted.

2.3.3.1.2 *Orange*: ASTM A653, Grade 33 structural steel, 10-gauge, minimum thickness 0.1419", painted.

2.3.4 Nuts:

2.3.4.1 *QTB(L) Blue* $3/16$ " diameter wire rope: $3/8$ " Grade 2 Hex Nuts

2.3.4.2 *QTO(L) Orange* $5/16$ " diameter wire rope: $5/8$ " Grade 2 Hex Nuts

2.4 For use of the QTS wall anchoring system in masonry construction, see Report Number [1404-06](#).

2.5 As needed, review material properties for design in **Section 6** and the regulatory evaluation in **Section 8**.

3 Definitions²

3.1 New Materials³ are defined as building materials, equipment, appliances, systems, or methods of construction, not provided for by prescriptive and/or legislatively adopted regulations, known as alternative materials.⁴ The design strength and permissible stresses shall be established by tests⁵ and/or engineering analysis.⁶

3.2 Duly authenticated reports⁷ and research reports⁸ are test reports and related engineering evaluations that are written by an approved agency⁹ and/or an approved source.¹⁰

3.2.1 This report utilizes intellectual property and/or trade secrets to create public domain material properties for commercial end-use.

3.2.1.1 This report protects confidential Intellectual Property and trade secrets under the regulation, [18.U.S.Code.90](#), also known as [Defend Trade Secrets Act of 2016](#) (DTSA).¹¹

3.3 An approved agency is "approved" when it is ANAB ISO/IEC 17065 accredited. DrJ Engineering, LLC (DrJ) is accredited and listed in the ANAB directory.

3.4 An approved source is "approved" when a professional engineer (i.e., Registered Design Professional, hereinafter RDP) is properly licensed to transact engineering commerce. The regulatory authority governing approved sources is the state legislature via its professional engineering regulations.¹²

3.5 Testing and/or inspections conducted for this duly authenticated report were performed by an ISO/IEC 17025 accredited testing laboratory, an ISO/IEC 17020 accredited inspection body, and/or a licensed RDP.

3.5.1 The Center for Building Innovation (CBI) is ANAB¹³ ISO/IEC 17025 and ISO/IEC 17020 accredited.

3.6 The regulatory authority shall enforce¹⁴ the specific provisions of each legislatively adopted regulation. If there is a non-conformance, the specific regulatory section and language of the non-conformance shall be provided in writing¹⁵ stating the nonconformance and the path to its cure.

3.7 The regulatory authority shall accept duly authenticated reports from an approved agency and/or an approved source with respect to the quality and manner of use of new materials or assemblies as provided for in regulations regarding the use of alternative materials, designs, or methods of construction.¹⁶

3.8 ANAB is an International Accreditation Forum (IAF) Multilateral Recognition Arrangement (MLA) signatory. Therefore, recognition of certificates and validation statements issued by conformity assessment bodies accredited by all other signatories of the IAF MLA with the appropriate scope shall be approved.¹⁷ Thus, all ANAB ISO/IEC 17065 duly authenticated reports are approval equivalent,¹⁸ and can be used in any country that is an MLA signatory found at this link: <https://iaf.nu/en/recognised-abs/>

3.9 Approval equity is a fundamental commercial and legal principle.¹⁹



4 Applicable Local, State, and Federal Approvals; Standards; Regulations²⁰

4.1 Local, State, and Federal

- 4.1.1 Approved in all local jurisdictions pursuant to ISO/IEC 17065 duly authenticated report use, which includes, but is not limited to, the following featured local jurisdictions: Austin, Baltimore, Broward County, Chicago, Clark County, Dade County, Dallas, Detroit, Denver, DuPage County, Fort Worth, Houston, Kansas City, King County, Knoxville, Las Vegas, Los Angeles City, Los Angeles County, Miami, Nashville, New York City, Omaha, Philadelphia, Phoenix, Portland, San Antonio, San Diego, San Jose, San Francisco, Seattle, Sioux Falls, South Holland, St. Louis County, Texas Department of Insurance, and Wichita.²¹
- 4.1.2 Approved in all state jurisdictions pursuant to ISO/IEC 17065 duly authenticated report use, which includes, but is not limited to, the following featured states: California, Florida, New Jersey, Oregon, New York, Texas, Washington, and Wisconsin.²²
- 4.1.3 Approved by the Code of Federal Regulations Manufactured Home Construction: Pursuant to Title 24, Subtitle B, Chapter XX, Part 3282.14²³ and Part 3280²⁴ pursuant to the use of ISO/IEC 17065 duly authenticated reports.
- 4.1.4 Approved means complying with the requirements of local, state, or federal legislation.

4.2 Regulations

- 4.2.1 *IBC – 18, 21, 24: International Building Code®*
- 4.2.2 *IRC – 18, 21, 24: International Residential Code®*
- 4.2.3 *FBC-B—20, 23: Florida Building Code²⁵ – Building*
- 4.2.4 *FBC-R—20, 23: Florida Building Code²⁵ – Residential*
- 4.2.5 *NCBC—18, 24: North Carolina Building Code*

4.3 Standards

- 4.3.1 *AISI S100: North American Specification for the Design of Cold-formed Steel Structural Members*
- 4.3.2 *ANSI/AISC 360: Specification for Structural Steel Buildings*
- 4.3.3 *ANSI/AWC NDS: National Design Specification (NDS) for Wood Construction*
- 4.3.4 *ASCE/SEI 7: Minimum Design Loads and Associated Criteria for Buildings and Other Structures*
- 4.3.5 *ASCE/SEI 19: Structural Applications of Steel Cables for Buildings*
- 4.3.6 *ASTM A36: Standard Specification for Carbon Structural Steel*
- 4.3.7 *ASTM A283: Standard Specification for Low and Intermediate Tensile Strength Carbon Steel Plates*
- 4.3.8 *ASTM A284: Specification for Low and Intermediate Tensile Strength Carbon-Silicon Steel Plates for Machine Parts and General Construction*
- 4.3.9 *ASTM A653: Standard Specification for Steel Sheet, Zinc-Coated (Galvanized) or Zinc-Iron Alloy-Coated (Galvannealed) by the Hot-Dip Process*
- 4.3.10 *ASTM A1011: Standard Specification for Steel, Sheet and Strip, Hot-Rolled, Carbon, Structural, High-Strength Low-Alloy, High-Strength Low-Alloy with Improved Formability, and Ultra-High Strength*
- 4.3.11 *ASTM A1023: Standard Specification for Carbon Steel Wire Ropes for General Purposes*
- 4.3.12 *ASTM F1667: Standard Specification for Driven Fasteners: Nails, Spikes, and Staples*



5 Listed²⁶

5.1 Equipment, materials, products, or services included in a List published by a nationally recognized testing laboratory (e.g., CBI), an approved agency (e.g., CBI and DrJ), and/or and approved source (e.g., DrJ), or other organization(s) concerned with product evaluation (e.g., DrJ), that maintains periodic inspection (e.g., CBI) of production of listed equipment or materials, and whose listing states either that the equipment or material meets nationally recognized standards or has been tested and found suitable for use in a specified manner.

6 Tabulated Properties Generated from Nationally Recognized Standards

6.1 Design

6.1.1 **Table 1** lists the maximum allowable tensile loads, based on Allowable Stress Design (ASD), of the QTS.

Table 1. Maximum Allowable Tensile Loads of the QTS

Cable Type	Cable Diameter (in)	Ultimate Tensile Capacity (lb)	Allowable Tensile Capacity ¹ (lb)
QTB(X) Blue	3/16	4,200	1,910
QTO(X) Orange	5/16	9,800	4,455

SI: 1 in = 25.4 mm, 1 lb = 4.45 N

- Allowable loads determined in accordance with ASCE 19 and a safety factor of 2.2. The QTS shall be installed in uncracked, normal-weight concrete. Supplementary reinforcement is not required to develop the tabulated loads of the QTS. However, concrete foundation shall be designed by an RDP.
- Minimum 28-day concrete compressive strength shall be 2,500-psi.

6.1.1.1 Multiple QuickTie cables of the same type may be used together to apply pre-stressing force, where one QuickTie cable is not sufficient.

6.1.1.2 Allowable loads are based on the published strength of the cables per ASTM A1023 using a safety factor of 2.2.

6.1.1.3 Construction documents shall include the information required by ASCE 19 Section 2.

6.1.2 Portal Frame with Hold-Down (PFH):

6.1.2.1 Use of Method PFH shall be in accordance with IRC Section R602.10.6.2 and IRC Figure R602.10.6.2, except that **Figure 4** shall be used to construct the PFH.

6.1.2.2 The maximum allowable tensile loads (based on Allowable Stress Design, ASD basis) of the QTS are presented in **Table 1**.

6.1.2.3 Two QuickTie Orange cables will be used to meet the required two (2) 3,500-lb hold-downs, with one (1) QuickTie Orange on each side of the pier.

6.1.2.4 QuickTie Blue cables will be used on the non-pier end of the portal frame where only a single 1,000-lb hold-down is required. The detail below using QTS is considered equivalent to the Method PFH detail of the IRC (**Figure 4**).

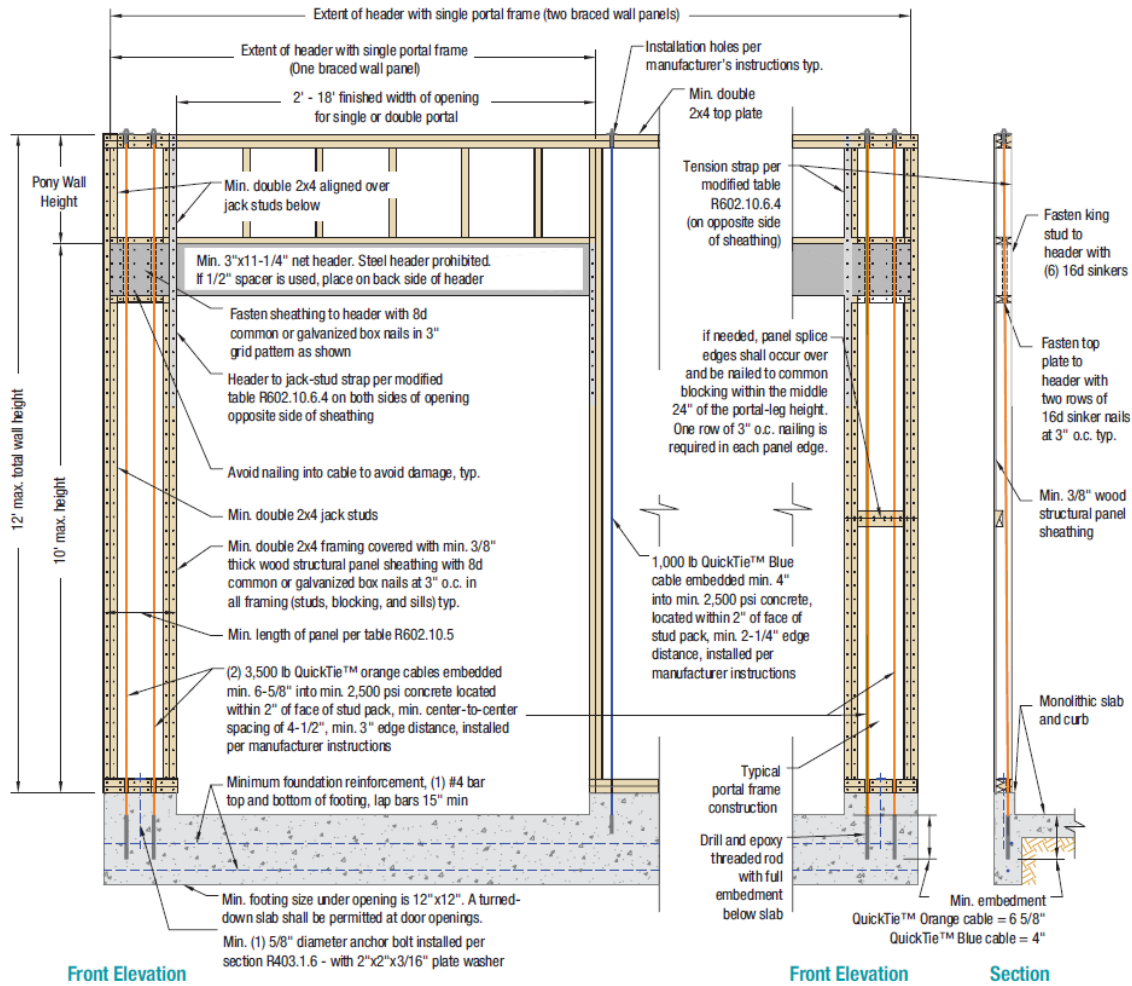

Figure 4. Diagram for Portal Frame with QuickTie Cables



6.1.2.5 Design parameters are presented in **Figure 5**.

MODIFIED TABLE R602.10.6.4 TENSION STRAP CAPACITY FOR RESISTING WIND PRESSURES PERPENDICULAR TO METHOD PFH

MINIMUM WALL STUD FRAMING NOMINAL SIZE AND GRADE	MAXIMUM POXY WALL HEIGHT (FT)	MAXIMUM TOTAL WALL HEIGHT (FT)	MAXIMUM OPENING WIDTH (FT)	ADJACENT TO QUICKTIE™ BLUE CABLE TENSION STRAP CAPACITY REQUIRED (LB) ^{1,2,3}						ADJACENT TO QUICKTIE™ ORANGE CABLE TENSION STRAP CAPACITY REQUIRED (LB) ^{1,2,3}						
				Ultimate Design Wind Speed, Vult (mph)						Ultimate Design Wind Speed, Vult (mph)						
				110	115	130	110	115	130	110	115	130	110	115	130	
				Exposure B			Exposure C			Exposure B			Exposure C			
2X4 No. 2 Grade	0	10	18	NR	NR	NR	NR	NR	NR	NR	NR	NR	NR	NR	NR	
			9	NR	NR	NR	NR	NR	750	NR	NR	NR	NR	NR	NR	
			16	NR	NR	1,050	1,075	1,500	2,950	NR	NR	NR	NR	NR	450	NR
	2	10	18	NR	275	1,375	1,400	1,850	DR	NR	NR	NR	NR	NR	DR	
			9	NR	NR	475	500	875	2,125	NR	NR	NR	NR	NR	NR	
			16	775	1,175	2,525	2,550	3,125	DR	NR	NR	NR	NR	625	DR	
		2	12	18	1,075	1,500	2,950	2,975	DR	DR	NR	NR	450	475	DR	DR
				9	150	500	1,650	1,675	2,175	DR	NR	NR	NR	NR	NR	DR
				16	1,875	2,375	DR	DR	DR	DR	NR	NR	DR	DR	DR	DR
	4	12	18	2,425	2,975	DR	DR	DR	DR	NR	475	DR	DR	DR	DR	
			9	1,275	1,750	DR	DR	DR	DR	NR	NR	DR	DR	DR	DR	
			12	2,225	2,775	DR	DR	DR	DR	NR	275	DR	DR	DR	DR	
2X8 Stud Grade	2	12	9	NR	NR	700	700	1,025	2,050	NR	NR	NR	NR	NR	NR	
			16	825	1,150	2,225	2,225	2,675	DR	NR	NR	NR	NR	175	DR	
			18	1,200	1,550	2,725	2,750	DR	DR	NR	NR	225	250	DR	DR	
	4	12	9	450	750	1,700	1,725	2,125	DR	NR	NR	NR	NR	NR	DR	
			16	1,050	1,400	DR	DR	DR	DR	NR	NR	DR	DR	DR	DR	
			18	2,350	2,800	DR	DR	DR	DR	NR	300	DR	DR	DR	DR	

NOTES:
 1. DR = Design Required
 2. NR = Not Required
 3. Straps shall be installed in accordance with manufacturer's recommendations.

Figure 5. Design Parameters for Portal Frame with QuickTie Cables

6.2 Alternative techniques shall be permitted in accordance with accepted engineering practice and experience. These provisions for the use of alternative materials, designs, and methods of construction are not intended to prevent the installation of any material or to prohibit any design or method of construction not specifically prescribed herein. This includes, but is not limited to, the following areas of engineering: mechanics of materials, structures, building science, and fire science.

7 Certified Performance²⁷

- 7.1 All construction methods shall conform to accepted engineering practices to ensure durable, livable, and safe construction and shall demonstrate acceptable workmanship reflecting journeyman quality of work of the various trades.²⁸
- 7.2 The strength and rigidity of the component parts and/or the integrated structure shall be determined by engineering analysis or by suitable load tests to simulate the actual loads and conditions of application that occur.²⁹

8 Regulatory Evaluation and Accepted Engineering Practice

- 8.1 QTS complies with the following legislatively adopted regulations and/or accepted engineering practice for the following reasons:
 - 8.1.1 Performance for use in buildings of light-frame construction and masonry is in accordance with the codes listed in **Section 4**.
 - 8.1.2 Compliance for use in buildings assigned to Seismic Design Categories A through E.
 - 8.1.3 Compliance for use in buildings located where basic design wind speed is less than or equal to 215 mph or the allowable stress design wind speed is less than or equal to 165 mph.
 - 8.1.4 Compliance for use as an alternative to the Portal Frame with Hold-Downs (PFH) detail as prescribed in IRC Section R602.10.6.2.



- 8.2 Any building code, regulation and/or accepted engineering evaluations (i.e., research reports, duly authenticated reports, etc.) that are conducted for this Listing were performed by DrJ, which is an ISO/IEC 17065 accredited certification body and a professional engineering company operated by RDP or approved sources. DrJ is qualified³⁰ to practice product and regulatory compliance services within its scope of accreditation and engineering expertise,³¹ respectively.
- 8.3 Engineering evaluations are conducted with DrJ's ANAB accredited ICS code scope of expertise, which is also its areas of professional engineering competence.

9 Installation

- 9.1 Installation shall comply with the approved construction documents, the manufacturer installation instructions, this report, and the applicable building code.
- 9.2 In the event of a conflict between the manufacturer installation instructions and this report, contact the manufacturer for counsel on the proper installation method.

10 Substantiating Data

- 10.1 Testing has been performed under the supervision of a professional engineer and/or under the requirements of ISO/IEC 17025 as follows:
- 10.1.1 Test Reports for Evaluation of QuickTie System (QTS) and Quick Connectors for QuickTie Assembly's Tension Load Strength and Elongation Properties (Pre-load and 30+ Day Relaxation).
 - 10.1.2 Engineering calculations and Allowable Load Verification Reports on the QuickTie System (QTS) for Allowable Design Loads, prepared by Qualtim, Inc.
 - 10.1.3 Engineering report for QuickTie used in a portal frame application, prepared by Qualtim, Inc.
- 10.2 Information contained herein may include the result of testing and/or data analysis by sources that are approved agencies, approved sources, and/or an RDP. Accuracy of external test data and resulting analysis is relied upon.
- 10.3 Where applicable, testing and/or engineering analysis are based upon provisions that have been codified into law through state or local adoption of regulations and standards. The developers of these regulations and standards are responsible for the reliability of published content. DrJ's engineering practice may use a regulation-adopted provision as the control. A regulation-endorsed control versus a simulation of the conditions of application to occur establishes a new material as being equivalent to the regulatory provision in terms of quality, strength, effectiveness, fire resistance, durability, and safety.
- 10.4 The accuracy of the provisions provided herein may be reliant upon the published properties of raw materials, which are defined by the grade mark, grade stamp, mill certificate, or duly authenticated reports from approved agencies and/or approved sources provided by the supplier. These are presumed to be minimum properties and relied upon to be accurate. The reliability of DrJ's engineering practice, as contained in this duly authenticated report, may be dependent upon published design properties by others.
- 10.5 *Testing and Engineering Analysis*
- 10.5.1 The strength, rigidity, and/or general performance of component parts and/or the integrated structure are determined by suitable tests that simulate the actual conditions of application that occur and/or by accepted engineering practice and experience.³²
- 10.6 Where additional condition of use and/or regulatory compliance information is required, please search for QTS on the DrJ Certification website.



11 Findings

- 11.1 As outlined in **Section 6**, the QTS has performance characteristics that were tested and/or meet applicable regulations. In addition, they are suitable for use pursuant to its specified purpose.
- 11.2 When used and installed in accordance with this duly authenticated report and the manufacturer installation instructions, QTS shall be approved for the following applications:
- 11.2.1 QTS and PFH are approved for use in Seismic Design Categories A through E.
 - 11.2.2 QTS and PFH are approved for use where the maximum allowable stress design wind speed is not more than 165 mph, or the maximum basic design wind speed is not more than 215 mph.
- 11.3 Unless exempt by state statute, when the QTS is to be used as a structural and/or building envelope component in the design of a specific building, the design shall be performed by an RDP.
- 11.4 Any application specific issues not addressed herein can be engineered by an RDP. Assistance with engineering is available from QuickTie Products, Inc.
- 11.5 IBC Section 104.2.3³³ (IRC Section R104.2.2³⁴ and IFC Section 104.2.3³⁵ are similar) in pertinent part state:
- 104.2.3 Alternative Materials, Design and Methods of Construction and Equipment.** The provisions of this code are not intended to prevent the installation of any material or to prohibit any design or method of construction not specifically prescribed by this code, provided that any such alternative is not specifically prohibited by this code and has been approved.
- 11.6 **Approved:**³⁶ Building regulations require that the building official shall accept duly authenticated reports.³⁷
- 11.6.1 An approved agency is “*approved*” when it is ANAB ISO/IEC 17065 accredited.
 - 11.6.2 An approved source is “*approved*” when an RDP is properly licensed to transact engineering commerce.
 - 11.6.3 Federal law, Title 18 US Code Section 242, requires that, where the alternative product, material, service, design, assembly, and/or method of construction is not approved, the building official shall respond in writing, stating the reasons why the alternative was not approved. Denial without written reason deprives a protected right to free and fair competition in the marketplace.
- 11.7 DrJ is a licensed engineering company, employs licensed RDPs and is an ANAB Accredited Product Certification Body – Accreditation #1131.
- 11.8 Through the IAF Multilateral Arrangement (MLA), this duly authenticated report can be used to obtain product approval in any jurisdiction or country because all ANAB ISO/IEC 17065 duly authenticated reports are equivalent.³⁸

12 Conditions of Use

- 12.1 As defined in **Section 6**, where material and/or engineering mechanics properties are created for load resisting design purposes, the resistance to the applied load shall not exceed the ability of the defined properties to resist those loads using the principles of accepted engineering practice.
- 12.2 Loads applied shall not exceed those recommended by the manufacturer as defined in this report.
- 12.3 Structural framing members (e.g., wood, masonry, concrete, steel) connected with the QTS and Quick Connectors shall be designed in accordance with the requirements of their specific design standards/specifications as referenced in the building code adopted by the jurisdiction in which the project is to be constructed.
- 12.4 Each QTS and/or PFH shipment shall contain the manufacturer installation instructions. A copy of the installation instructions must be available at the jobsite at all times during installation.
- 12.5 The QTS shall be installed by contractors trained and certified by QuickTie Products, Inc.



- 12.6 The QTS and Quick Connectors that are exposed directly to weather, or subject to salt corrosion in coastal areas as determined by the local building official, shall be protected in accordance with the building code adopted by the jurisdiction in which the project is to be constructed.
- 12.7 When required by adopted legislation and enforced by the building official, also known as the Authority Having Jurisdiction (AHJ) in which the project is to be constructed:
- 12.7.1 Any calculations incorporated into the construction documents shall conform to accepted engineering practice and, when prepared by an approved source, shall be approved when signed and sealed.
 - 12.7.2 This report and the installation instructions shall be submitted at the time of permit application.
 - 12.7.3 These innovative products have an internal quality control program and a third-party quality assurance program.
 - 12.7.4 At a minimum, these innovative products shall be installed per **Section 9**.
 - 12.7.5 The review of this report by the AHJ shall comply with IBC Section 104.2.3.2 and IBC Section 105.3.1.
 - 12.7.6 These innovative products have an internal quality control program and a third party quality assurance program in accordance with IBC Section 104.7.2, IBC Section 110.4, IBC Section 1703, IRC Section R104.7.2, and IRC Section R109.2.
 - 12.7.7 The application of these innovative products in the context of this report is dependent upon the accuracy of the construction documents, implementation of installation instructions, inspection as required by IBC Section 110.3, IRC Section R109.2, and any other regulatory requirements that may apply.
- 12.8 The approval of this report by the AHJ shall comply with IBC Section 1707.1, where legislation states in part, *“the building official shall make, or cause to be made, the necessary tests and investigations; or the building official shall accept duly authenticated reports from approved agencies in respect to the quality and manner of use of new materials or assemblies as provided for in Section 104.2.3”*, all of IBC Section 104, and IBC Section 105.3.
- 12.9 Design loads shall be determined in accordance with the regulations adopted by the jurisdiction in which the project is to be constructed and/or by the building designer (i.e., owner or RDP).
- 12.10 The actual design, suitability, and use of this report for any particular building, is the responsibility of the owner or the authorized agent of the owner.

13 Identification

- 13.1 The QuickTie System (QTS) Portal Frame with Hold-Downs (PFH), as listed in **Section 1.1**, are identified by a label on the board or packaging material bearing the manufacturer name, product name, this report number, and other information to confirm code compliance.
- 13.2 Additional technical information can be found at quicktieproducts.com.

14 Review Schedule

- 14.1 This report is subject to periodic review and revision. For the latest version, visit www.drjcertification.org.
- 14.2 For information on the status of this report, please contact DrJ Certification.



Issue Date: February 18, 2022
Supplement Revision Date: March 11, 2026
Subject to Renewal: April 1, 2027

FBC Supplement to Report Number 1506-20

REPORT HOLDER: QuickTie™ Products, Inc.

1 Evaluation Subject

1.1 The QuickTie System (QTS)

2 Purpose and Scope

2.1 Purpose

2.1.1 The purpose of this Report Supplement is to show QTS, recognized in Report Number 1506-20, have also been evaluated for compliance with the codes listed below as adopted by the Florida Building Commission.

2.2 *Applicable Code Editions*

2.2.1 *FBC-B—20, 23: Florida Building Code – Building*

2.2.2 *FBC-R—20, 23: Florida Building Code – Residential*

3 Conclusions

3.1 QTS, described in Report Number 1506-20, complies with the FBC-B and FBC-R and is subject to the conditions of use described in this supplement.

3.2 Where there are variations between the IBC and IRC and the FBC-B and FBC-R applicable to this report, they are listed here:

- 3.2.1 FBC-B Section 104 is reserved.
- 3.2.2 FBC-B Section 110.4 is reserved and replaces IBC Section 110.4.
- 3.2.3 FBC-B Section 104.6 is reserved and replaces IBC Section 104.4.
- 3.2.4 FBC-B Section 104.11 replaces IBC Section 104.2.3 and Section 104.2.3.2.
- 3.2.5 FBC-B Section 105.3 replaces IBC Section 105.3.
- 3.2.6 FBC-B Section 105.3.1 replaces IBC Section 105.3.1.
- 3.2.7 FBC-B Section 110.3 replaces IBC Section 110.3.
- 3.2.8 FBC-B Section 1707.1 replaces IBC Section 1707.1.
- 3.2.9 FBC-B Section 2306.1 replaces IBC Section 2306.1.
- 3.2.10 FBC-B Section 2306.3 replaces IBC Section 2306.3.
- 3.2.11 FBC-R Section R104 and Section R109 are reserved.
- 3.2.12 FBC-R Section R602.10.6.2 is reserved and replaces IBC Section R602.10.6.2.



4 Conditions of Use

4.1 QTS, described in Report Number 1506-20, must comply with all of the following conditions:

- 4.1.1 All applicable sections in Report Number 1506-20.
- 4.1.2 The design, installation, and inspections are in accordance with additional requirements of FBC-B Chapter 16 and Chapter 17, as applicable.



- 30 Qualification is performed by a legislatively defined Accreditation Body. ANSI National Accreditation Board (ANAB) is the largest independent accreditation body in North America and provides services in more than 75 countries. DrJ is an ANAB accredited product certification body.
- 31 <https://anabpd.ansi.org/Accreditation/product-certification/AllDirectoryDetails?prgID=1&orgID=2125&statusID=4#:~:text=Bill%20Payment%20Date-.Accredited%20Scopes,-13%20ENVIRONMENT.%20HEALTH>
- 32 See Code of Federal Regulations (CFR) Title 24 Subtitle B Chapter XX Part 3280 for definition: <https://www.ecfr.gov/current/title-24/subtitle-B/chapter-XX/part-3280>
- 33 2021 IBC Section 104.11
- 34 2021 IRC Section R104.11
- 35 2018: <https://up.codes/viewer/wyoming/ifc-2018/chapter/1/scope-and-administration#104.9> AND 2021: <https://up.codes/viewer/wyoming/ibc-2021/chapter/1/scope-and-administration#104.11>
- 36 Approved is an adjective that modifies the noun after it. For example, Approved Agency means that the Agency is accepted officially as being suitable in a particular situation. This example conforms to IBC/IRC/IFC Section 201.4 (<https://up.codes/viewer/mississippi/ibc-2024/chapter/2/definitions#201.4>) where the building code authorizes sentences to have an ordinarily accepted meaning such as the context implies.
- 37 <https://up.codes/viewer/mississippi/ibc-2024/chapter/17/special-inspections-and-tests#1707.1>
- 38 Multilateral approval is true for all ANAB accredited product evaluation agencies and all International Trade Agreements.